

Directional Control Valve

Technical Information

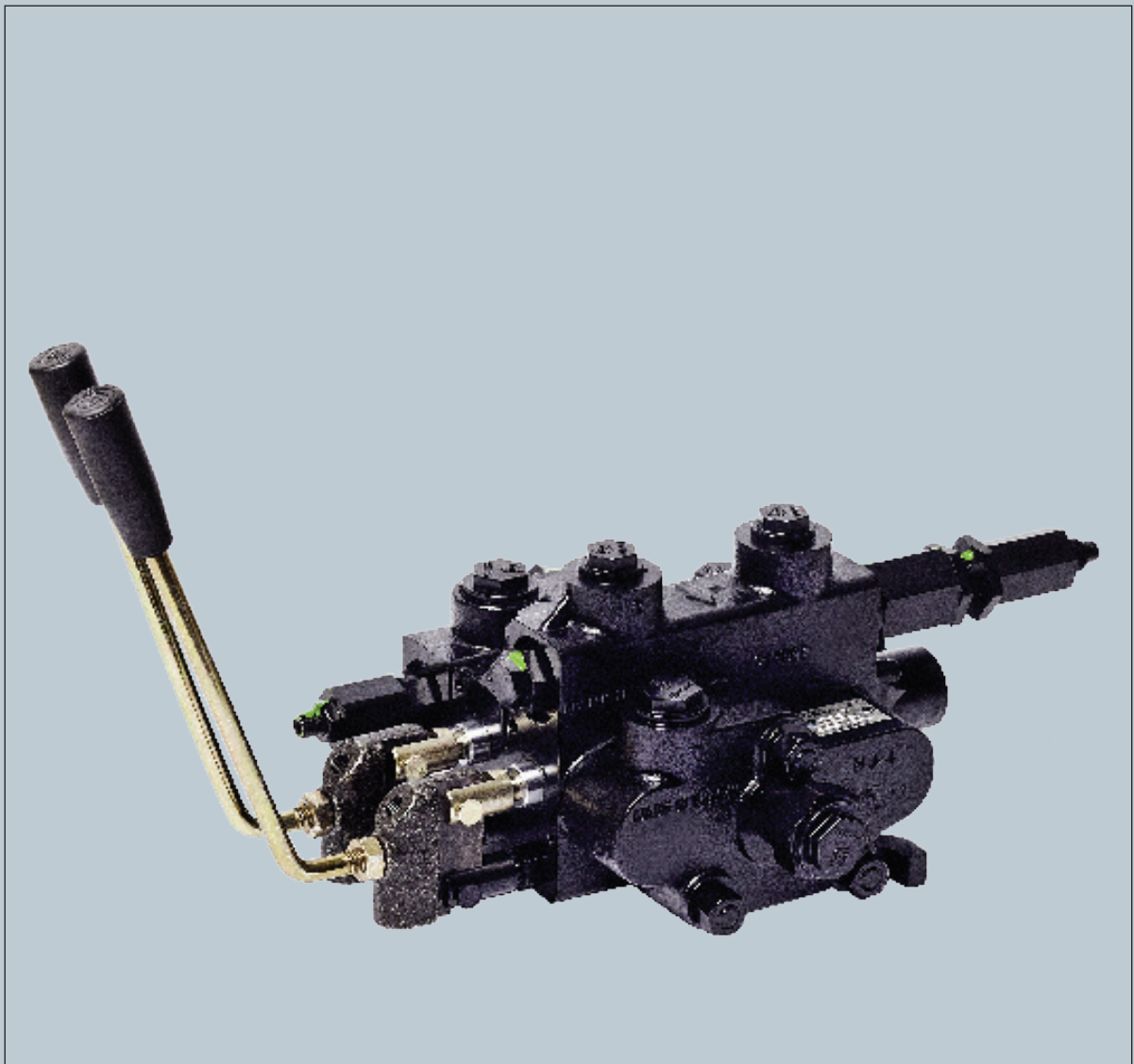

Directional Control Valves Technical Information: Contents

PRODUCT OVERVIEW	Flexibility of design.....	3
	Circuit options	3
	Capability	3
	Actuation options	3
	Modular valves	4
FLUIDS AND FILTRATION		
	Fluids.....	5
	Base stock and additives	5
	Viscosity.....	5
	Filtration	5
	Return line filtration.....	5
	Cleanliness	5
CDS 60 AND 100		
	Specifications.....	6
	Typical performance	7
	Inlet covers order code.....	8
	Inlet porting and relief valve options.....	9
	Mid-inlet flow dividers and combiners order code.....	10
	Mid-inlet flow dividers and combiners.....	11
	Outlet covers order code	12
	Outlet porting and plug options	13
	Work section order code.....	14-17
	Circuit types.....	18
	Spool types.....	19
	Actuation options	20-21
	Cabling and electrical options for actuator types G, H, and J	22
	Actuation mounting side	22
	Spool centering and detent options	23-24
	Auxiliary valves.....	25-26
	Dimensions CDS 100.....	26
	Dimensions CDS 60	27
APPENDIX 1 — ORDER FORMS		
	Spool valve order form	28
	CDS60 and CDS100 specification worksheet.....	28
	CDS60 and CDS100 price worksheet	28

Directional Control Valves Technical Information: Product overview

FLEXIBILITY OF DESIGN The Danfoss directional control valves are designed to give customer flexibility over a broad range of flow and pressure capabilities. Actuator options include a range of levers, cable actuators, hydraulic and pneumatic pilot controls, two-axis joysticks, and electrohydraulic solenoids. Flow rates range from 0 to 100 l/min [26 US gal/min].

CIRCUIT OPTIONS

- Parallel circuits
- Series circuits
- Tandem circuits
- Priority circuits
- Regenerative circuits
- Power beyond

CAPABILITY

- Flow rates from 0 to 100 l/min [26 US gal/min]
- System pressure up to 250 BAR
- Up to 12 work sections
- 12 cm³/min [0.7 in³/min] leakage

ACTUATION OPTIONS

- Handles and levers
- Mechanical two-axis joystick
- Spool ends
- **ElectroHydraulic Control (EHC)** on/off solenoid
- Cable control
- Pneumatic pilot control
- Dual spool ends

MODULAR VALVES

Valve model	l/min [US gal/min]					Number of Spools	Circuit	Page
	20 [5]	40 [11]	60 [16]	80 [21]	100 [26]			
CDS-100						100 [26]	1 to 12	Parallel Tandem Series
CDS-60				60 [16]			1 to 12	Parallel Tandem Series

 Indicates Maximum Working Pressure Rated At 210 bar [3000 psi]

FLUIDS

Hydraulic fluid performs three basic functions in a hydraulic system: It transfers energy, lubricates moving components, and transports heat and contaminants out of the system.

Base stock and additives

Danfoss valves are designed to operate with mineral-based fluids containing oxidation, rust, and foam inhibitors, compatible with fluoroelastomer seals. Consult your fluid supplier for information on seal compatibility.

Viscosity

Viscosity is the most important property of a hydraulic fluid. It is a measurement of how the fluid resists flow. Low viscosity fluids increase internal leakage; high viscosity fluids increase pressure drop through the valve. Use a fluid that meets the viscosity limits published in this catalog. For specific requirements, see technical data in each section.

Temperature

Temperature affects a fluid's viscosity. Higher temperature fluid has lower viscosity. Operating at excessive temperatures may have other detrimental effects on your hydraulic fluid. Design your hydraulic system to operate within the specified temperature range. Specific requirements are published in each section.

For more information

For more information on hydraulic fluid selection refer to *Hydraulic Fluids and Lubricants Technical Information*, Danfoss publication **520L0463**.

FILTRATION

Effective filtration is critical to a hydraulic system's performance and working life. Employ system filtration capable of meeting the published requirements in each valve section. Be aware that other components in the system may have more stringent requirements. Design your filtration system to satisfy the requirements of the most sensitive component.

Return line filtration

Return line filtration is generally adequate for Danfoss valves. We recommend a 10 micron nominal (20 micron absolute) or finer filter. Insure the filter in your system is properly sized and maintained. To facilitate proper filter maintenance, use a pressure gauge or other indicator to signal when it is necessary to change the filter. Never allow filter to reach its bypass condition. Follow the filter manufacturer's maintenance recommendations.

Cleanliness

Hydraulic system contamination must not exceed the limits published for each valve. Limits are specified per ISO 4406 (1999). When measuring system contamination, calibrate test equipment in accordance with the ACFTD method.

For more information

For more information on system filtration, refer to *Design Guidelines for hydraulic fluid cleanliness*, Danfoss publication **520L0467**.

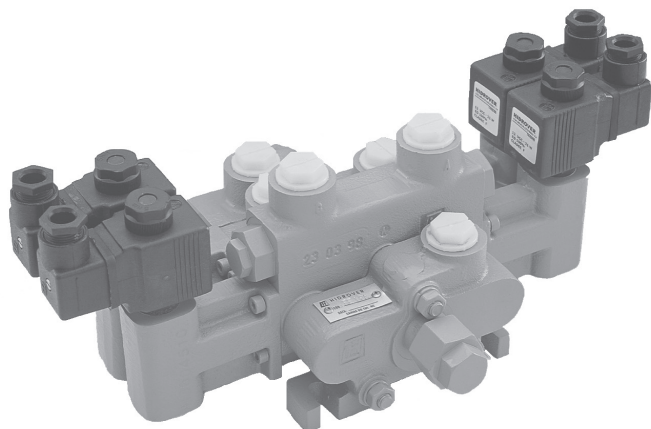

CDS 100

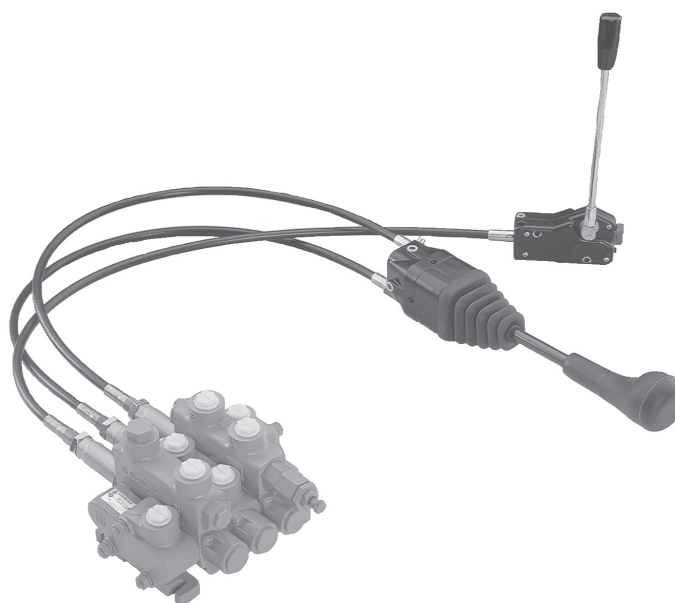

CDS 60

SPECIFICATIONS

Maximum flow (CDS 100)	100 l/min [26.4 US gal/min]
Maximum flow (CDS 60)	60 l/min [15.8 US gal/min]
Work pressure	210 bar [3050 psi]
Maximum pressure	250 bar [3625 psi]
Maximum pressure (outlet section)	40 bar [580 psi]
Temperature range	-40° to 80° C [-40 to 176° F]
Recommended fluid type	Mineral based hydraulic oil
Recommended viscosity	26-55 mm ² /sec (cSt) [123-255 SUS]
Minimum fluid cleanliness (per ISO 4406)	19/16

Directional Control Valves Technical Information: CDS 60 and 100

TYPICAL PERFORMANCE *Pressure vs. flow curves for main relief valve*

Based on oil temperature of 45°–50°C [113°–122° F]. Viscosity 32 mm²/sec (cSt) [151 SUS]. CDS spool leakage (standard) at 70 bar [1015 psi], 50°C [122°F], ISO VG46: 10 cm³/min [0.61 in³/min]

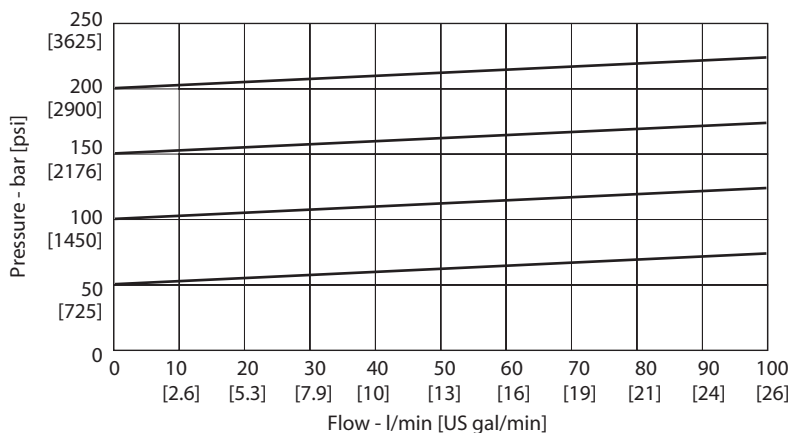

Pressure drop (P-T) CDS 60

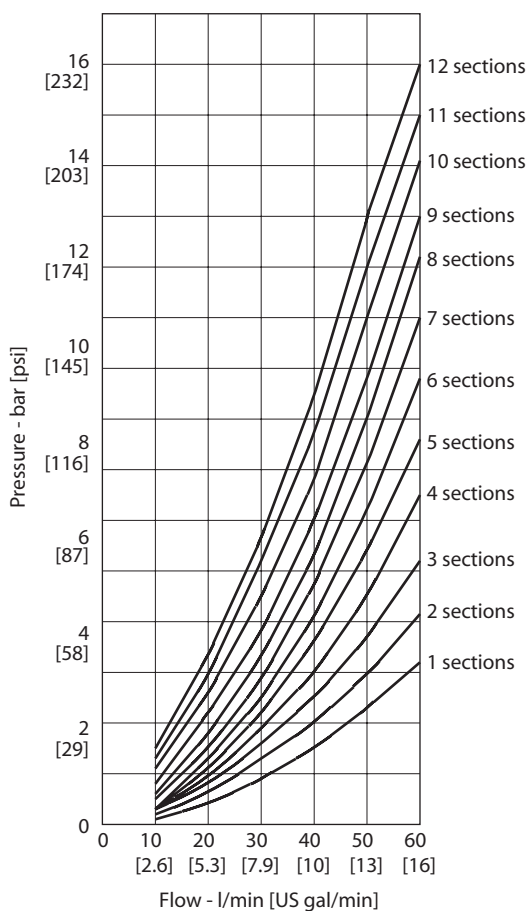

Pressure drop (P-T) CDS 100

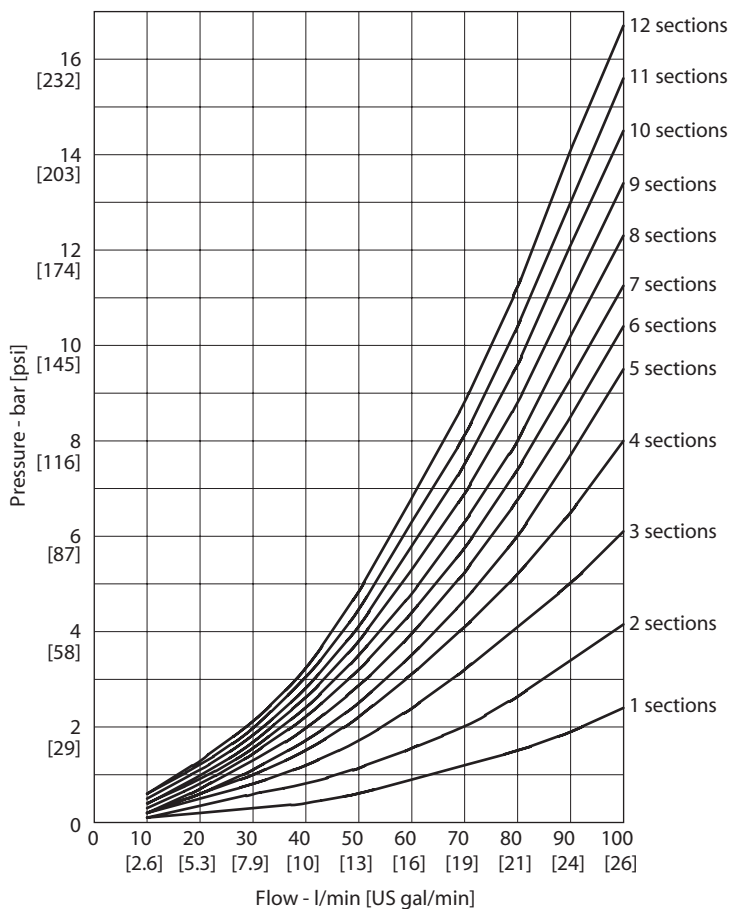

Directional Control Valves Technical Information: CDS 60 and 100

INLET COVERS ORDER CODE

Inlet covers order code (example)

E60 A C 2 140/40*

Models

Code	Description
E100	CDS100
E60	CDS60

Port locations

Code	Description
A	Top port
B	Side port, top port plugged
C	Top port, with side gauge port (9/16-18UNF)
D	Top inlet and outlet ports (use H, I, J on outlet)

Main relief valves

Code	Description
A	No valve, with plastic plug
B	No valve, with special plug
C	Valve, with direct valve and external adjustment
D	Valve, with direct valve and internal adjustment
E*	Valve, pilot operated and external adjustment

* on request

Port types

Code		1	2	3	4	5	7	8	X
Threads		SAE - ORB			BSP - Parallel		Metric - ISO 6149		Special porting, specify
		#8 3/4 -16UNF	#10 7/8 -14UNF	#12 1 1/16-12UNF	3/8 -19	1/2 -14	M18x1.5	M22x1.5	
Model CDS100	Inlet outlet		●	●		○		○	
	Section		●	●		○		○	
Model CDS60	Inlet outlet	●	●		○	○	○	○	
	Section	●	●		○	○	○	○	

● available
○ on request

INLET PORTING AND RELIEF VALVE OPTIONS

Inlet covers order code (example)

E60 A C 2 140/40*

Port location

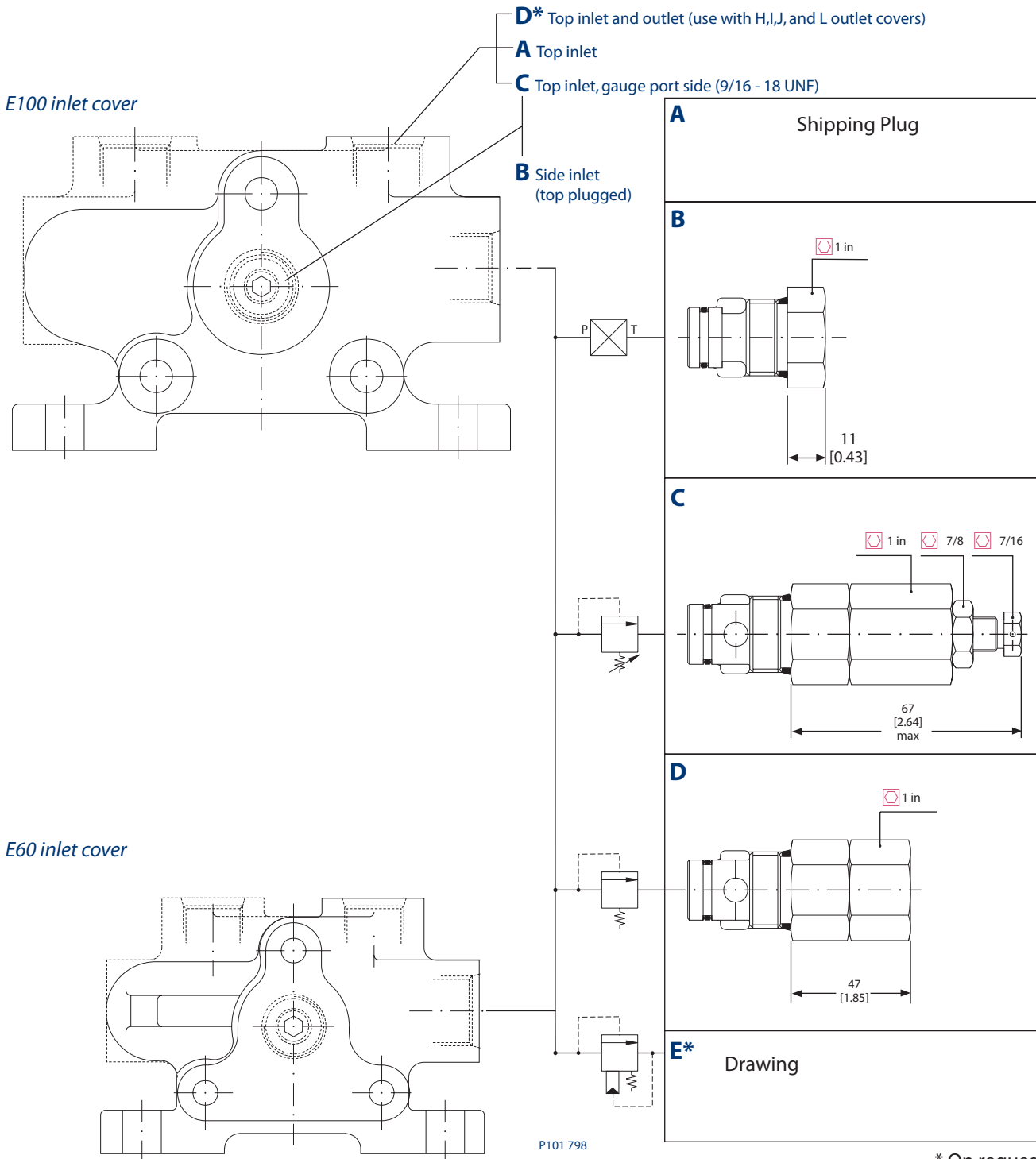

* On request

mm [in]

Directional Control Valves Technical Information: CDS 60 and 100

OUTLET COVERS ORDER CODE

Outlet covers order code (example)

S60 **A 2**

Models

Code	Description
S100	CDS 100
S60	CDS 60

Ports

Code	Description
A	Top outlet
B	Side outlet, top plugged
C	Side outlet for power beyond (top to tank)
D	Top outlet (with closed bypass)
E	Top outlet (for electrical control)
F	Top outlet (for electrical control, with power beyond)
G	Side outlet (for electrical control, top plugged)
H*	Top plugged
I*	Top plugged, use with power beyond
J*	Top plugged for electrical control
L*	Top plugged for electrical control, use with power beyond

* On request (use D on inlet)

Port types

Code		1	2	3	4	5	7	8	X
Threads		SAE - ORB			BSP - Parallel		Metric - ISO 6149		Special porting, specify
		#8 3/4 -16UNF	#10 7/8 -14UNF	#12 1 1/16-12UNF	3/8 -19	1/2 -14	M18x1.5	M22x1.5	
Model	outlet		●	●		○		○	
Model	outlet	●	●		○	○	○	○	
CDS100			●	●		○		○	
CDS60		●	●		○	○	○	○	

● available

○ on request

OUTLET PORTING AND PLUG OPTIONS

Outlet covers order code (example)

S60 A 2

S100 outlet cover

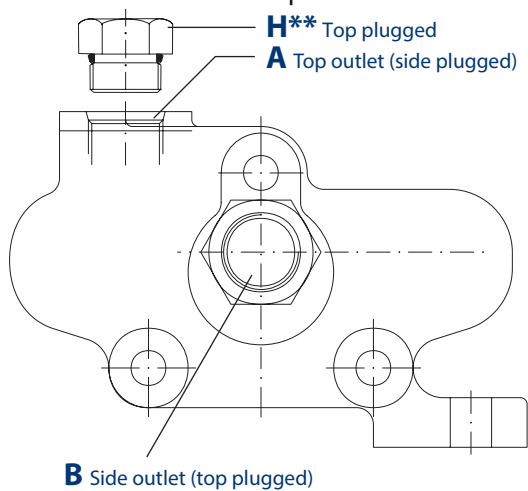

S60 outlet cover

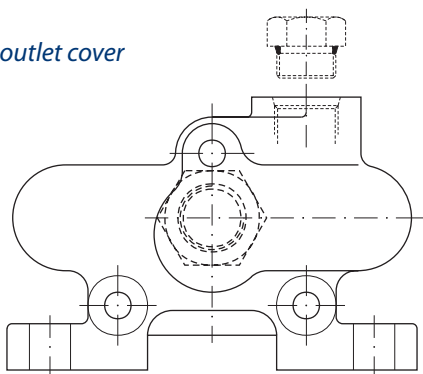

P101 799E

mm [in]

C		
I		
D*		
E		
J		
F		
L		
G		

*Typically used for high pressure standby.

** On request

WORK SECTION ORDER CODE

Work section order code (example)

A100	1	A	E	2	A	1	A	B	A100	140/40*
------	---	---	---	---	---	---	---	---	------	---------

Model

A100	CDS 100 body for supporting valves
B100	CDS 100 normal body (no valves)
A60	CDS 60 body for supporting valves
B60	CDS 60 normal body (no valves)

Circuit types, page 15

1	Parallel (no priority)
2*	Tandem (priority)
3*	Series (no priority)

Spool types, page 16

A	4-way, closed center
B	4-way, open center
C	4-way, closed center, port A plugged
D	4-way, closed center, port B plugged
E	3-way, closed center, port A plugged
F	3-way, closed center, port B plugged
G	4-way, open center, port A plugged
H	4-way, open center, port B plugged
I	Float-spool in (use centering option J)
J	Float-spool out (use centering option J)

Spool actuation, pages 17–18

A	No extension
B	Female spool end + Clevis
C	Male spool end + Tang
D	With support (no lever)
E	With lever
F	Pneumatic (use centering option A)
G	Cable with lever
H	Cable with joystick (use A for the adjacent body)
I/M	With mechanical joystick (use A for the adjacent body)
J	Electrical
R	Female spool end
S	Male spool end
T	Female Spool end with adjust

Spool actuation mounting side, page 20

1	Actuator mounted on A port side
2	Actuator mounted on B port side
3	Electrical A and B (use L centering type)

See cabling and electrical options, page 22.

* On request

Directional Control Valves Technical Information: CDS 60 and 100

WORK SECTION ORDER CODE (continued)

Work section order code (example)

A100 | **1 A E 2 A 1** | **A B** | **A100** | **140/40***

Spool centering and detents, page 20-21

A	Spring centered
B	3 position detent
C	Spring centered, detent in A
D	Spring centered, detent in B
E	Spring centered, detent in A and B
F	Spring centered, hydraulic kickout
H	Spring centered, female extension
I	Spring centered, male extension
J	Spring centered, detent in float: use for floatation spool
L	Spring centered, use for electrical command
N	2-position detent, spool in
O	2-position detent, spool out
P*	With switch, activates spool in
Q*	With switch, activates spool in and out
R*	With switch, activates two motors

* on request

Port types

Code		1	2	3	4	5	7	8	X
Threads		SAE - ORB			BSP - Parallel		Metric - ISO 6149		Special porting, specify
		#8 3/4 -16UNF	#10 7/8 -14UNF	#12 1 1/16-12UNF	3/8 -19	1/2 -14	M18x1.5	M22x1.5	
Model CDS100	Section		●	●		○		○	
Model CDS60	Section	●	●			○	○	○	

● available
○ on request

Auxiliary valves, page 22-23

A	Plug
B	Direct relief with external adjustment (except electrical actuation)
C	Direct relief with internal adjustment
D	Pilot check valve
E*	Flow control valve (Except electrical actuation)
F	Anti-cavitation
G	Direct relief with anti-cavitation and external adjustment (except electrical actuation)
I	Direct relief with anti-cavitation and internal adjustment (electrical only)
J	Plug, for 3-way spools
K	Plug, for valves D and E

For valves B, C, G, and I, specify pressure and flow
Example: **B(140/40)** Pressure 140 bar flow 40 l/min



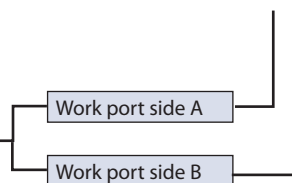













* On request



ACTINGS AND CENTERING COMBINATIONS AVAILABLE

Actings

Centerings

	A	B	C	D	E	F	G	H	I/M	J
A		●	●	●	●	●	●	●	●	●
B		●	●	●	●	●	●	●	●	●
C		●	●	●	●	●	●	●	●	●
D		●	●	●	●	●	●	●	●	●
E		●	●	●	●	●	●	●	●	●
F		●	●	●	●	●	●	●	●	●
G		●	●	●	●	●	●	●	●	●
H		●	●	●	●	●	●	●	●	●
I		●	●	●	●	●	●	●	●	●
J		●	●	●	●	●	●	●	●	●
L										●
N		●	●	●	●	●	●	●	●	●
O		●	●	●	●	●	●	●	●	●
P		●	●	●	●	●	●	●	●	●
Q		●	●	●	●	●	●	●	●	●
R		●	●	●	●	●	●	●	●	●

● available

CIRCUIT TYPES

Work section order code (example)

A100	1	A	E	2	A	1	A	B	A100	140/40*
------	---	---	---	---	---	---	---	---	------	---------

1 Parallel circuit (no priority)

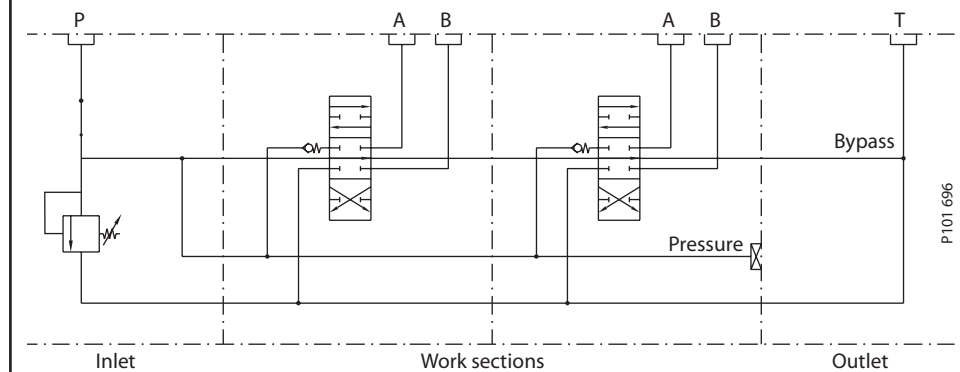

When two or more sections operate simultaneously, flow favors the lowest pressure.

2 Tandem circuit (priority)*

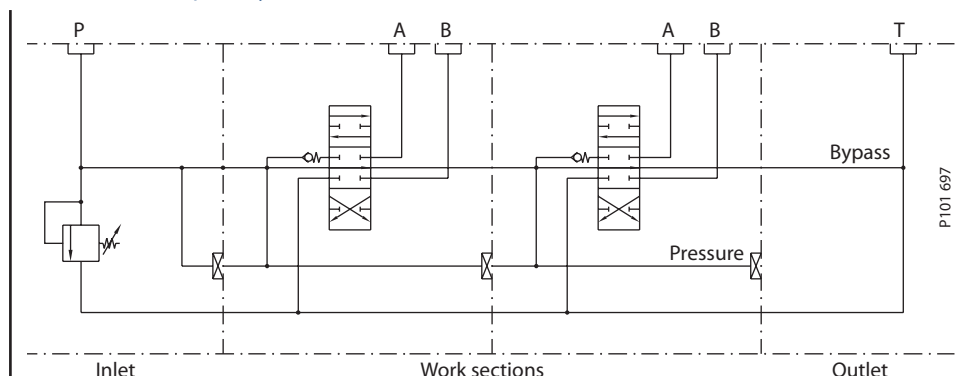

When two or more sections operate simultaneously, only the section closest to the inlet receives flow.

3 Series circuit (no priority)*

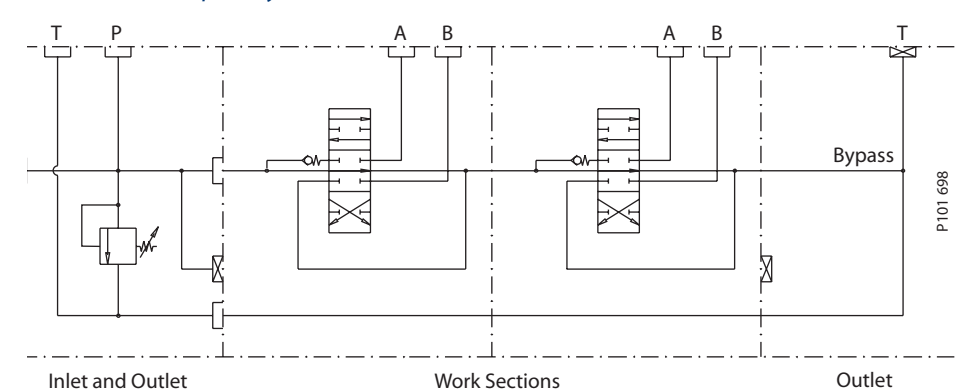

When two or more sections operate simultaneously, the section closest to the inlet receives flow. Return flow feeds the sections downstream.

* on request

SPOOL TYPES

Work section order code (example)

A100 | **1 A E 2 A 1** | **A B** | **A100** | **140/40***

Standard central body

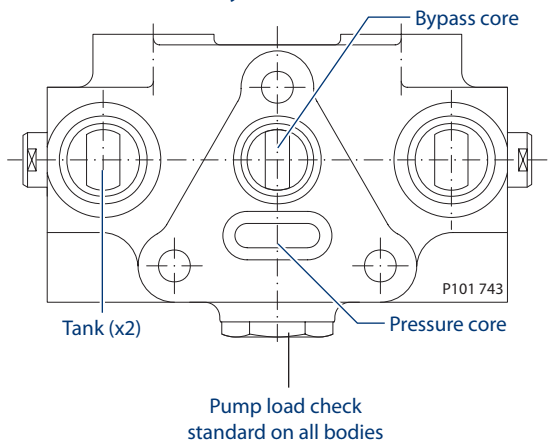

Central body for use with auxiliary valves

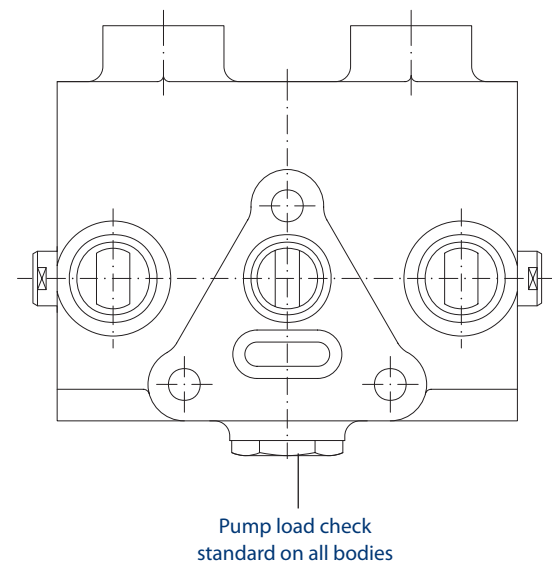

Ref.	Description	Symbol
A	4-way closed center	
B	4-way open center	
C	4-way closed center port A plugged	
D	4-way closed center port B plugged	
E	3-way closed center port A plugged	
F	3-way closed center port B plugged	
G	4-way open center port A plugged	
H	4-way open center port B plugged	
I	Float spool in (inner inverter)	
J	Float spool out (outer inverter)	

ACTUATION OPTIONS

Work section order code (example)
A100 1 A E 2 A 1 A B A100 140/40*

A Without spool end

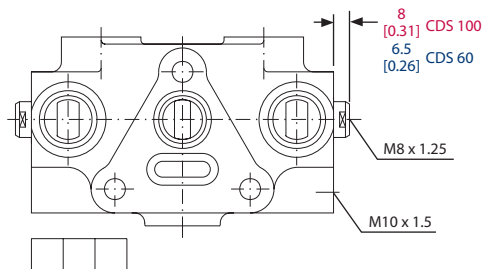

B Female spool end (clevis)

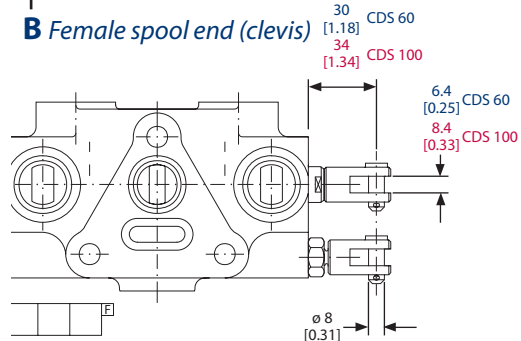

C Male spool end (tang)

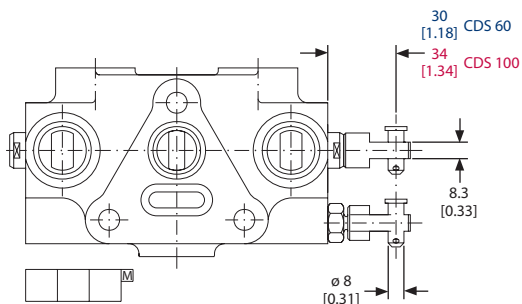

D With support

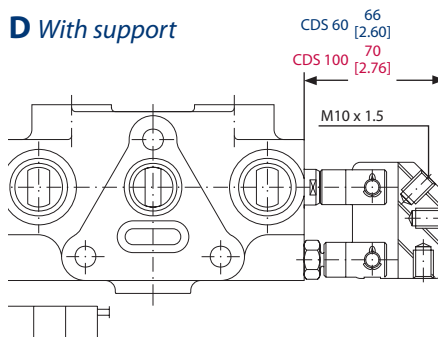

E With lever

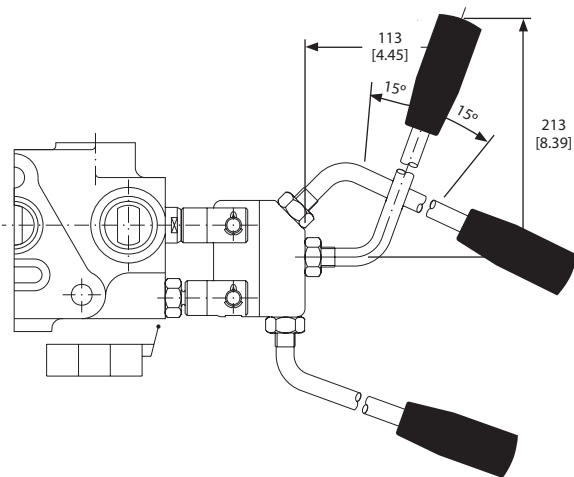

F Pneumatic

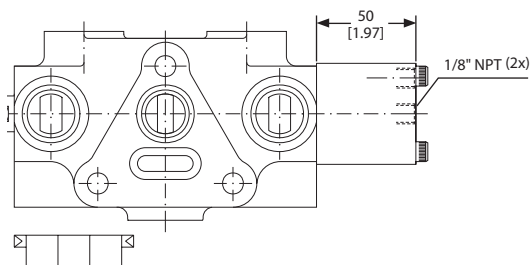

Minimum air pressure CDS 60: 5 bar [73 psi]
 Minimum air pressure CDS 100: 8 bar [116 psi]
 Maximum air pressure: 12 bar [174 psi]

mm [in]

* Default relief setting if not specified

ACTUATION OPTIONS (continued)

Work section order code (example)

A100	1	A	E	2	A	1	A	B	A100	140/40*
------	---	---	---	---	---	---	---	---	------	---------

G Cable with lever**

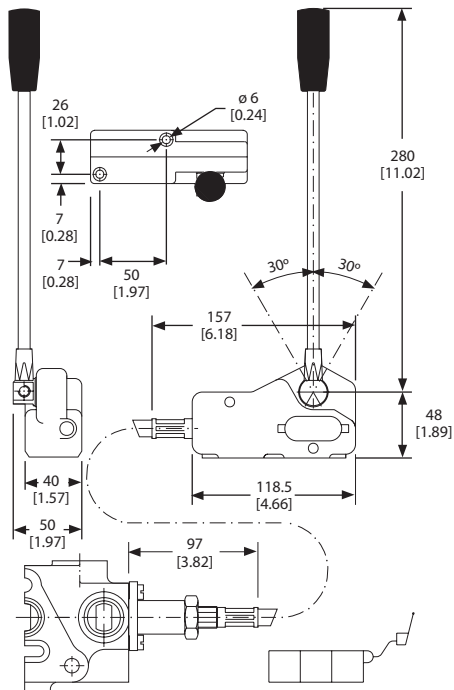

H Cable with joystick**

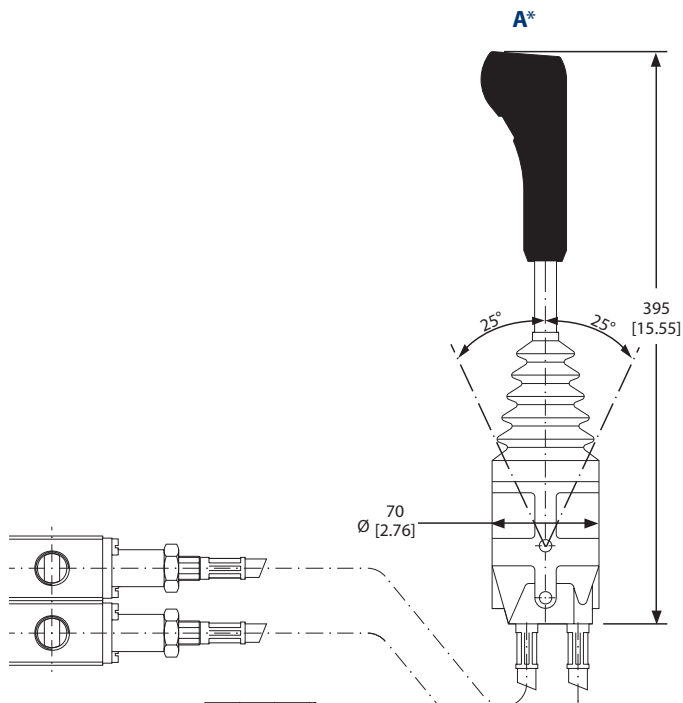

I/M Mechanical joystick

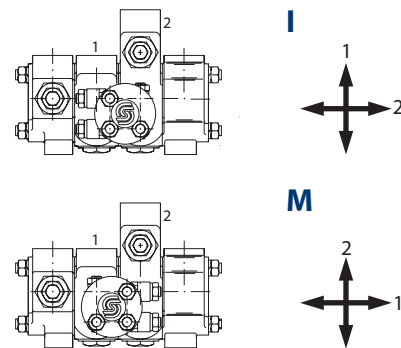
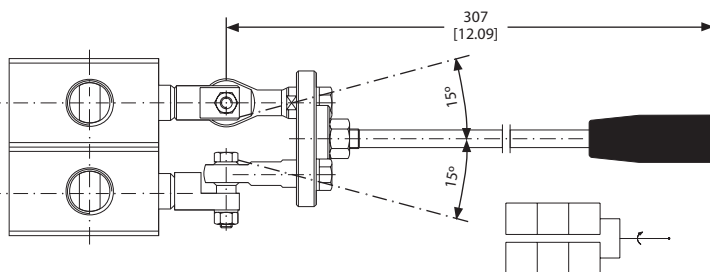

J Electrical**

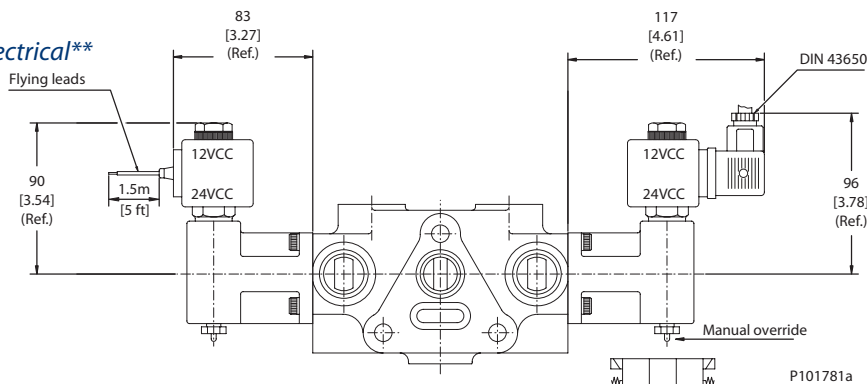

**See cabling and electrical options, page 20.
Standard sections cannot be converted to electrical due to internal pilot.
Minimum pilot pressure to actuate: 35 bar [500 psi]

mm [in]

CABLING AND ELECTRICAL OPTIONS FOR ACTUATOR TYPES G, H, AND J

Work section order code (example)

A100	1	A	E	2	A	1	A	B	A100	140/40*
------	---	---	---	---	---	---	---	---	------	---------

G: Flexible cable and lock options for spool control lever

	A	B	C
Lever lock options	Without lock	Lock in A and/or B	Lock in central position
Standard cables	100 - 125 - 150 - 175 - 200 - 250 - 275 - 300 - 325 - 350 - 400 - 450 - 500 cm (other: consult)		
Example: how to order	A60 - 1AG2A1 - AB - A100 - 140/40 (lever without lock, 100 cm cable)		

H: Flexible cable and handle options controls for joystick

	A
Joystick handle options	Without switches
Standard cables	100 - 125 - 150 - 175 - 200 - 250 - 275 - 300 - 325 - 350 - 400 - 450 - 500 cm (other: consult)
Example: how to order	A60 - 1AH2A1 - AB - A100 - 140/40 (handle without switches, 100 cm cable)

J: Electrical spool voltage and termination options

Voltage	A	B	E	F
	12 VDC - lead wires	24 VDC - lead wires	12 VDC - DIN 43650 conn.	24 VDC - DIN 43650 conn.
Example: how to order	A60 - 1AJ3L1 - AC - A 140/40 (12 VDC coil with lead wires)			

Force requirements

kgf [lbf]	CDS 60	CDS 100
Push/pull min.	2 [4.4]	3.5 [7.7]
Max. tension	250 [551]	250 [551]

Electrical specifications

Voltage	Amperage (A)	Resistance (Ω)
12 VDC	1.75	6.85
24 VDC	0.88	27
Power: 21 W		

ACTUATION MOUNTING SIDE

1 Actuation on A port side (RH inlet shown)

2 Actuation on B port side (LH inlet shown)

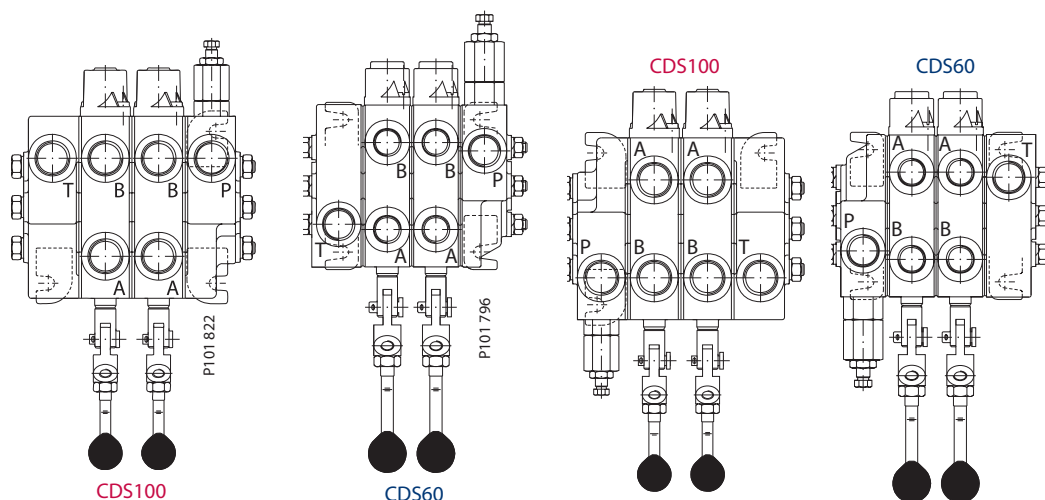

SPOOL CENTERING AND DETENT OPTIONS

Work section order code (example)

A100 1 A E 2 A 1 A B A100 140/40*

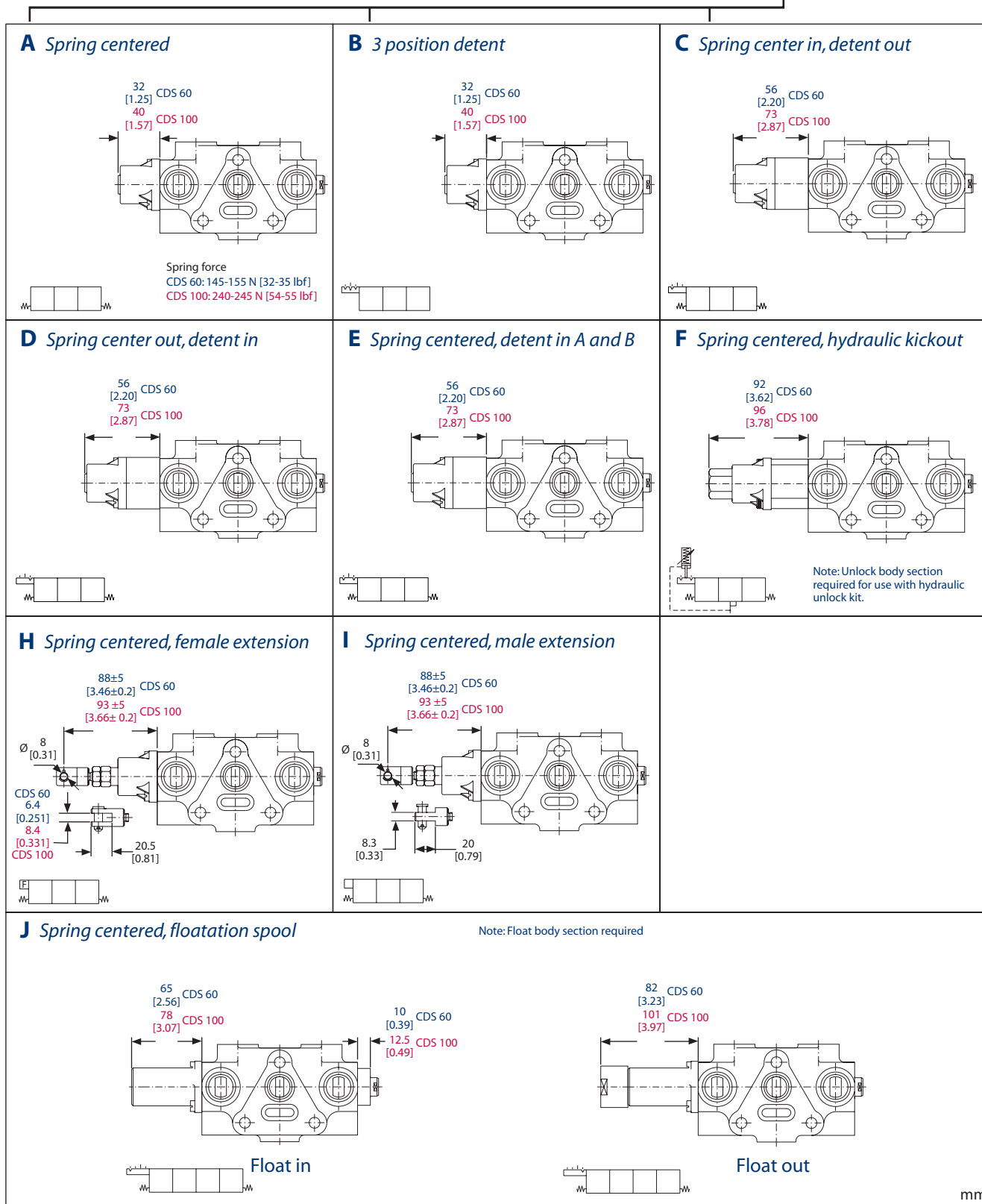

mm [in]

* Default relief setting if not specified

Directional Control Valves Technical Information: CDS 60 and 100

SPOOL CENTERING AND DETENT OPTIONS (continued)

Work section order code (example)

A100 1 A E 2 A 1 A B A100 140/40*

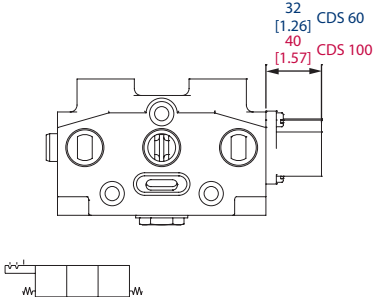
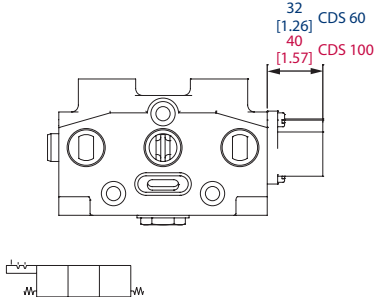
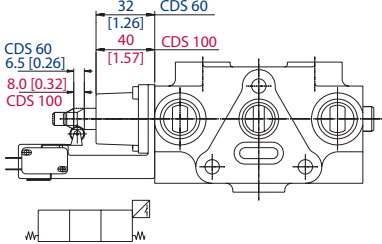
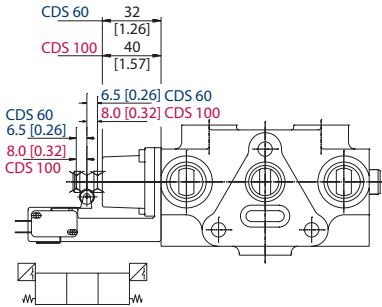
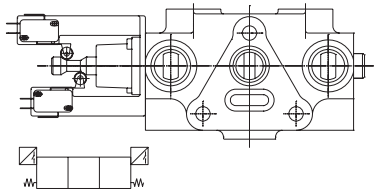
	<p>N Two-position detent: neutral and spool in</p> 	<p>O Two-position detent: neutral and spool out</p> 
<p>P* Spring centered with switch: activates on spool in</p> 	<p>Q* Spring centered with switch: activates on spool in and out</p> 	<p>R* Spring centered with switch: activates two motors</p> 

*on request

P106 330E

AUXILIARY VALVES

Work section order code (example)

A100 1 A E 2 A 1 A B A100 140/40*

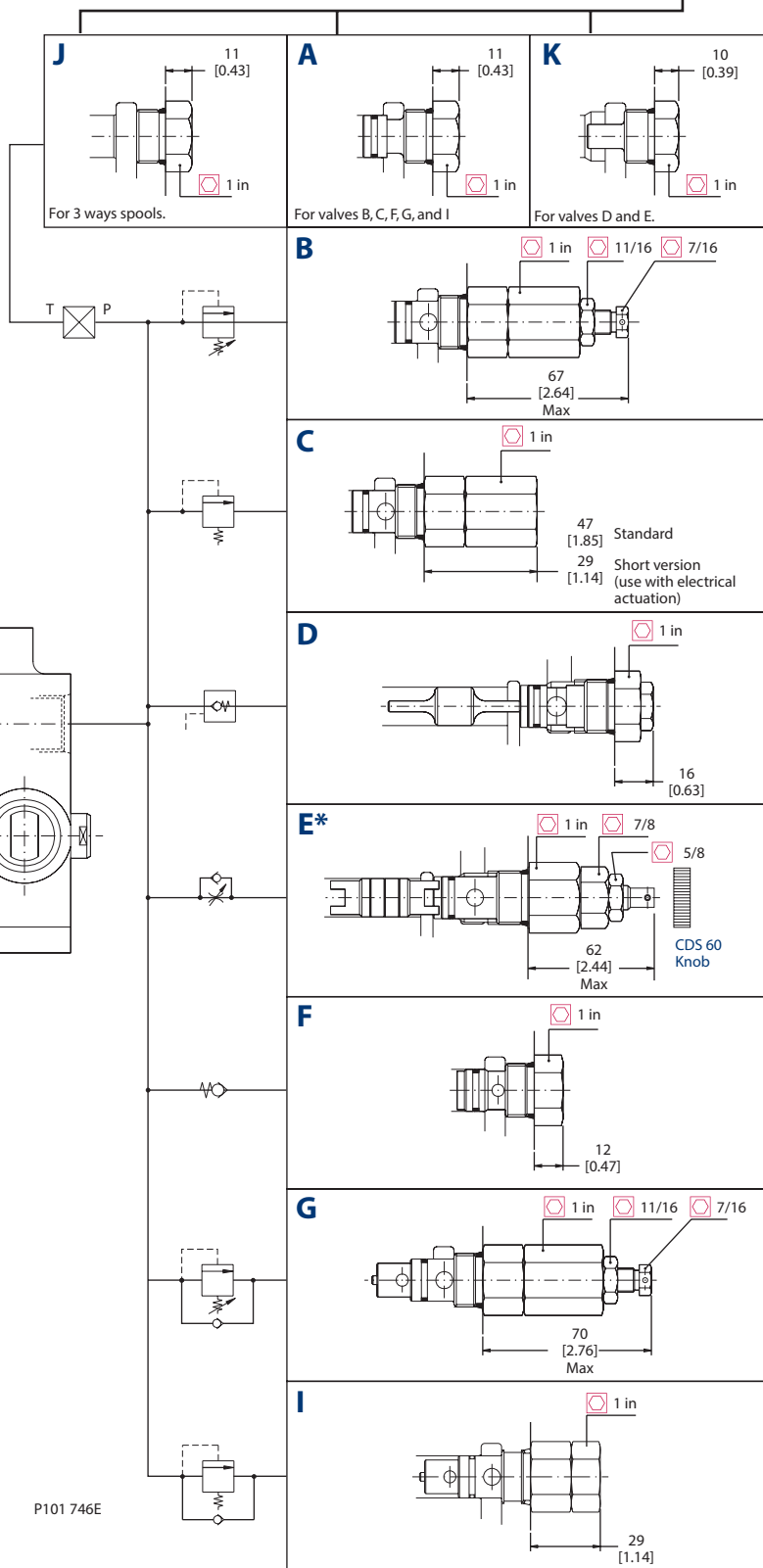

Central body for use with auxiliary valves

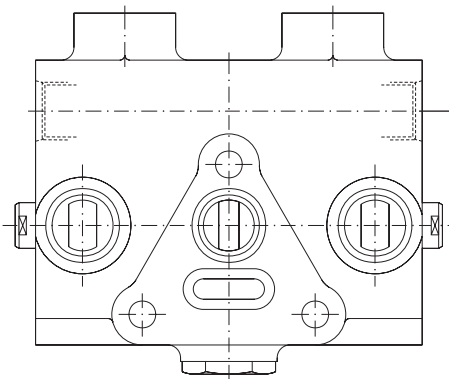

mm [in]

Directional Control Valves Technical Information: CDS 60 and 100

AUXILIARY VALVES (continued)

Work section order code (example)

A100 1 A E 2 A 1 A B A100 140/40*

Auxiliary valves compatibility

	A	B	C	D	E	F	G	I	J	K
A	■	●	■	—	—	■	●	▲	—	—
B	●	●	●	—	—	●	●	—	●	—
C	■	●	■	—	—	■	●	▲	●	—
D	—	—	—	■	—	—	—	—	—	■
E	—	—	—	—	■	—	—	—	—	■
F	■	●	■	—	—	■	●	▲	●	—
G	●	●	●	—	—	●	●	—	●	—
I	▲	—	▲	—	—	▲	—	▲	▲	—
J	—	●	●	—	—	●	●	▲	▲	—
K	—	—	—	■	■	—	—	—	—	■

— Not compatible

■ Compatible

● Compatible (EXCEPT electrical)

▲ Compatible (ONLY electrical)

DIMENSIONS CDS 100

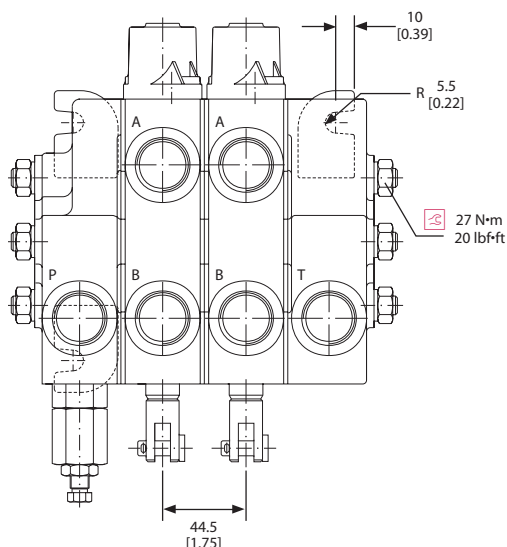
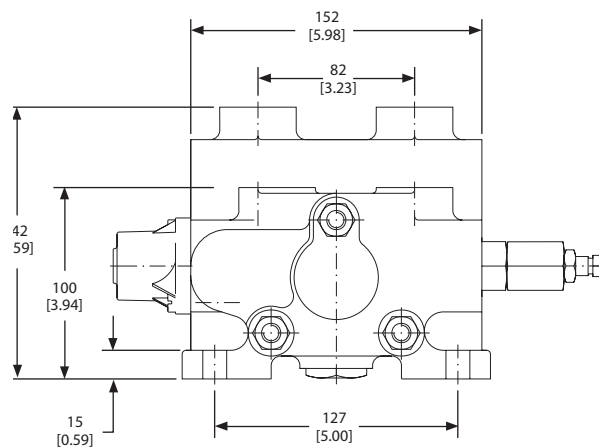
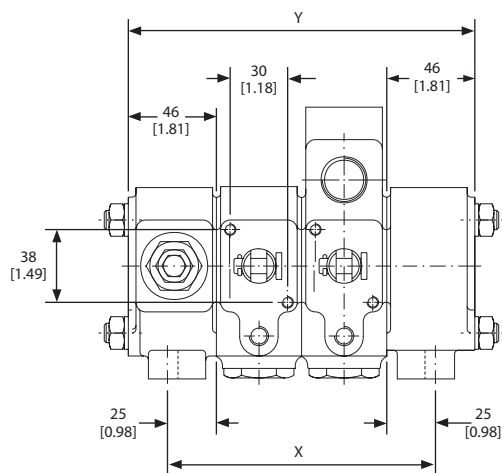

Reference dimensions

Number of sections	X	Y
1	95 [3.74]	137 [5.39]
2	139 [5.47]	181 [7.13]
3	184 [7.24]	226 [8.89]
4	229 [9.02]	270 [10.63]
5	273 [10.75]	314 [12.36]
6	318 [12.52]	359 [14.13]
7	362 [14.25]	403 [15.87]
8	406 [15.98]	448 [17.64]
9	451 [17.76]	492 [19.37]
10	495 [19.49]	537 [21.14]
11	540 [21.26]	581 [22.87]
12	584 [22.99]	626 [24.65]

mm [in]

DIMENSIONS CDS 60

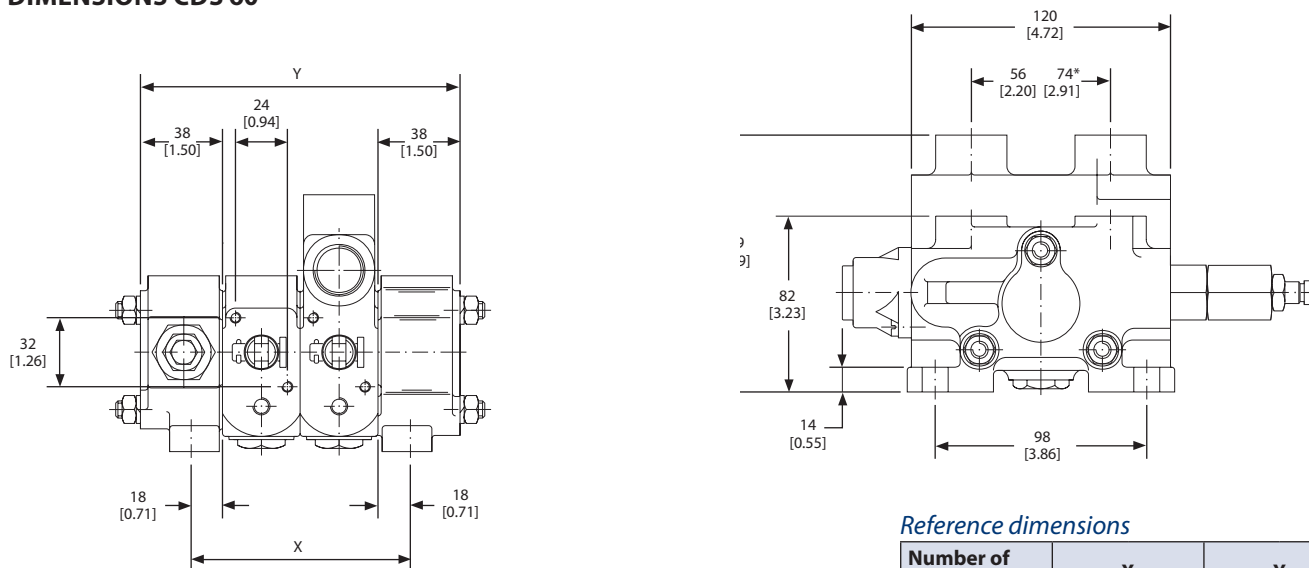

Reference dimensions

Number of sections	X		Y	
1	72	[2.83]	112	[4.41]
2	108	[4.25]	148	[5.83]
3	144	[5.67]	184	[7.42]
4	180	[7.09]	220	[8.66]
5	216	[8.50]	256	[10.08]
6	252	[9.92]	292	[11.50]
7	288	[11.34]	328	[12.91]
8	324	[12.76]	364	[14.33]
9	360	[14.17]	400	[15.75]
10	396	[15.59]	436	[17.17]
11	432	[17.01]	472	[18.58]
12	468	[18.43]	508	[20.00]

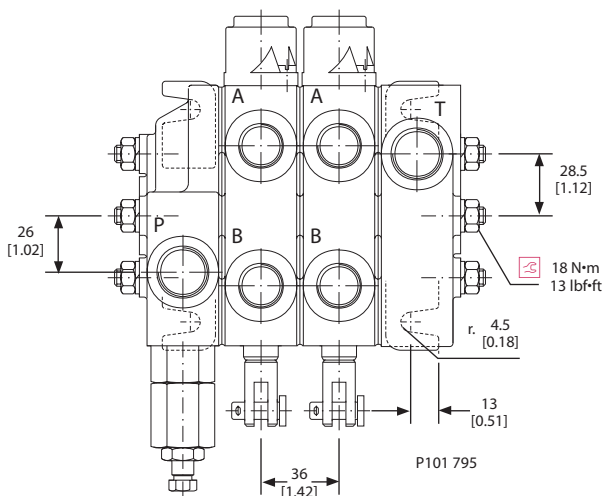

Mounting requirements

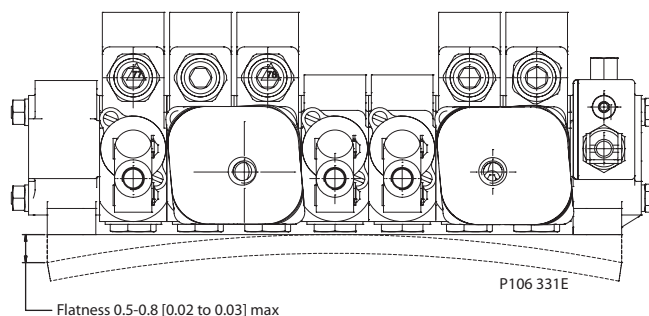
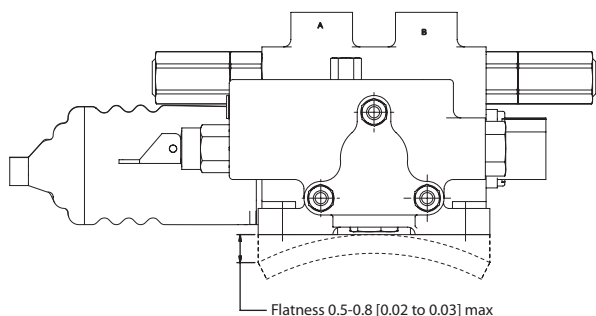



CDS60 AND CDS100 SPECIFICATION WORKSHEET

<h2 style="margin: 0;">Directional Control Valves CDS60 and CDS100 Specification Order Form</h2>												Control No.				
Customer												Subsidiary/Dealer				
Application																
Inlet Section												Outlet Section				
Model	Model Side	Port Size	Main relief Valves	Threads	Port Side Pressure	Port Side Flow	Model	Model Size	Ports Options	Threads						
Paint																
None																
Black Primer																
Black Paint																
Work Sections																
Work section	Model	Model Size	Circuit Type	Spool Types	Spool Controls	Spool Control Side	Center Type	Threads	Aux Valves "A"	Aux Valves "B"	Cable or Electrical Control Options	Cable Length Centi-meters	"A" Port Side Pressure (Bar)	"A" Port Side Flow (l/min)	"B" Port Side Pressure (Bar)	"B" Port Side Flow (l/min)
1st																
2nd																
3rd																
4th																
5th																
6th																
7th																
8th																
9th																
10th																
11th																
12th																
Number of sections =																
Price US \$:																
Delivery:																
Date:																

OUR PRODUCTS

- Hydrostatic transmissions
- Hydraulic power steering
- Electric power steering
- Electrohydraulic power steering
- Closed and open circuit axial piston pumps and motors
- Gear pumps and motors
- Bent axis motors
- Orbital motors
- Transit mixer drives
- Planetary compact gears
- Proportional valves
- Directional spool valves
- Cartridge valves
- Hydraulic integrated circuits
- Hydrostatic transaxles
- Integrated systems
- Fan drive systems
- Electrohydraulics
- Microcontrollers and software
- Electric motors and inverters
- Joysticks and control handles
- Displays
- Sensors

**Danfoss Mobile Power and Control Systems
– Market Leaders Worldwide**

Danfoss is a comprehensive supplier providing complete systems to the global mobile market.

Danfoss serves markets such as agriculture, construction, road building, material handling, municipal, forestry, turf care, and many others.

We offer our customers optimum solutions for their needs and develop new products and systems in close cooperation and partnership with them.

Danfoss specializes in integrating a full range of system components to provide vehicle designers with the most advanced total system design.

Danfoss provides comprehensive worldwide service for its products through an extensive network of Global Service Partners strategically located in all parts of the world.

Local address:

Danfoss (US) Company
2800 East 13th Street
Ames, IA 50010, USA
Phone: +1 515 239-6000
Fax: +1 515 239-6618

Danfoss GmbH & Co. OHG
Postfach 2460, D-24531 Neumünster
Krokamp 35, D-24539 Neumünster, Germany
Phone: +49 4321 871-0
Fax: +49 4321 871 122

Danfoss ApS
DK-6430 Nordborg, Denmark
Phone: +45 7488 4444
Fax: +45 7488 4400

Danfoss-Daikin LTD
Sannomiya Grand Bldg. 8F
2-2-21 Isogami-dori, Chuo-ku
Kobe, Hyogo 651-0086, Japan
Phone: +81 78 231 5001
Fax: +81 78 231 5004

Danfoss can accept no responsibility for possible errors in catalogues, brochures and other printed material. Danfoss reserves the right to alter its products without notice. This also applies to products already on order provided that such alterations can be made without subsequential changes being necessary in specifications already agreed. All trademarks in this material are property of the respective companies. Danfoss and the Danfoss logotype are registered trademarks of Danfoss A/S. All rights reserved.