

MAKING MODERN LIVING POSSIBLE

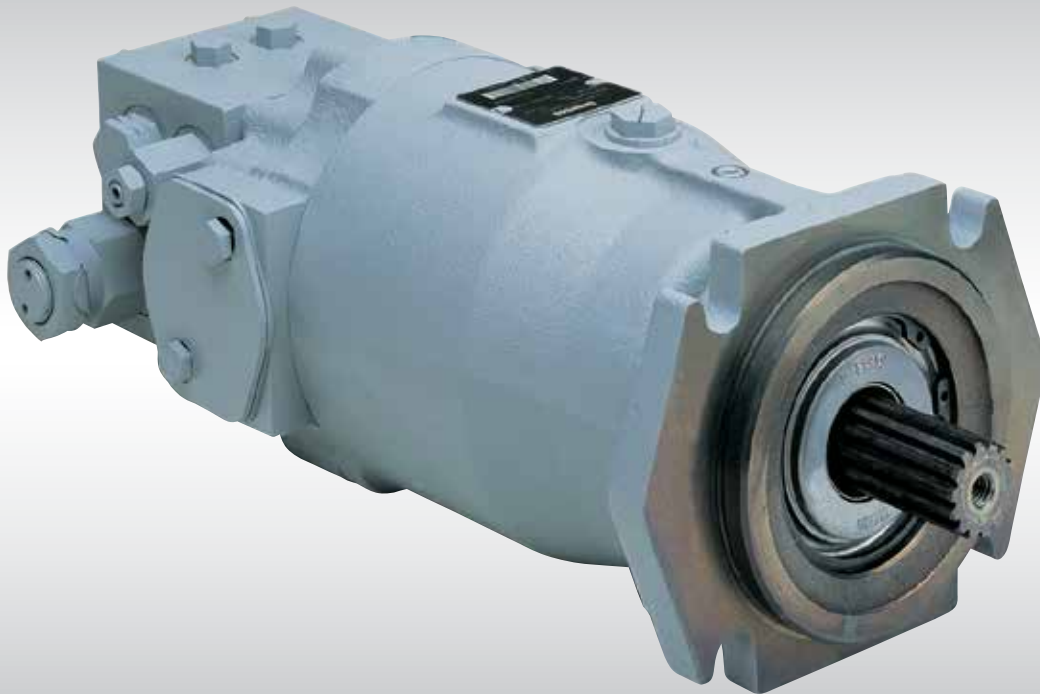

Technical Information

# Axial Piston Motors Series 20



**General Information****Introduction**

Danfoss a world leader in hydraulic power systems has developed a family of axial piston motors.

**Description**

Danfoss axial pistons fixed displacement motors are of swash plate design with preset displacement suitable for hydrostatic transmissions with closed loop circuit.  
The output speed is proportional to the motor's input flow.  
The output torque is proportional to the differential pressure applied to the main pressure ports.  
The direction of motor (output) shaft rotation depends on flow input to the main pressure ports.

Danfoss axial piston fixed displacement motors are well engineered and easy to handle.  
The full-length shaft with a highly efficient tapered roller bearing arrangement offers a high loading capacity for external radial forces.  
High case pressures can be achieved without leakage even at the lowest temperatures by using suitable shaft seals.  
Danfoss axial piston units are designed for easy servicing. Complete dismantling and reassembly can be carried out with standard hand tools, and all components or sub-assemblies are replaceable.  
Axial piston fixed displacement motors of the Danfoss pattern are made by licensed producers worldwide, providing consistent service and fully inter-changeable parts.

**Typical markets**

- Industrial
- Mining
- Transit Mixer
- Utility Vehicles

---

**Technical Information      Axial Piston Motors Series 20**

---

**Contents**

<b>General Description</b>	Introduction .....	2
	Description .....	2
	Typical markets .....	2
<b>Sectional View</b>	Axial piston fixed displacement motor.....	4
<b>System Circuit Description</b>	Pump and motor circuit description.....	5
	Motor circuit schematic .....	5
<b>Technical Specification</b>	Technical parameters .....	6
	Design .....	6
	Type of mounting .....	6
	Pipe connections.....	6
	Direction of rotation and flow.....	6
	Installation position .....	6
	External drain fluid loss .....	6
	Hydraulic parameters .....	7
	System pressure range, input $p_1$ .....	7
	System pressure range, output $p_2$ .....	7
	Case pressure.....	7
	Hydraulic fluid .....	7
	Hydraulic fluid temperature range.....	7
	Viscosity range.....	7
	Filtration .....	7
Shaft load .....	7	
Determination of nominal motor size.....	8	
<b>Dimensions</b> – <b>Frame Size 070 and 089</b>	Outline drawing, configuration ms .....	9
	Outline drawing, basic model.....	11
	Outline drawing, motor configuration am 01000.....	11
	Outline drawing, motor configuration mr.....	12
	Circuit diadrams.....	13
	Configuration MR.....	13
	Basic model and motor configuration AM 01000 .....	13
<b>Dimensions</b> – <b>Frame Size 227 and 334</b>	Outline drawing, configuration ms .....	14

General Description

Axial piston fixed displacement motor

Sectional View

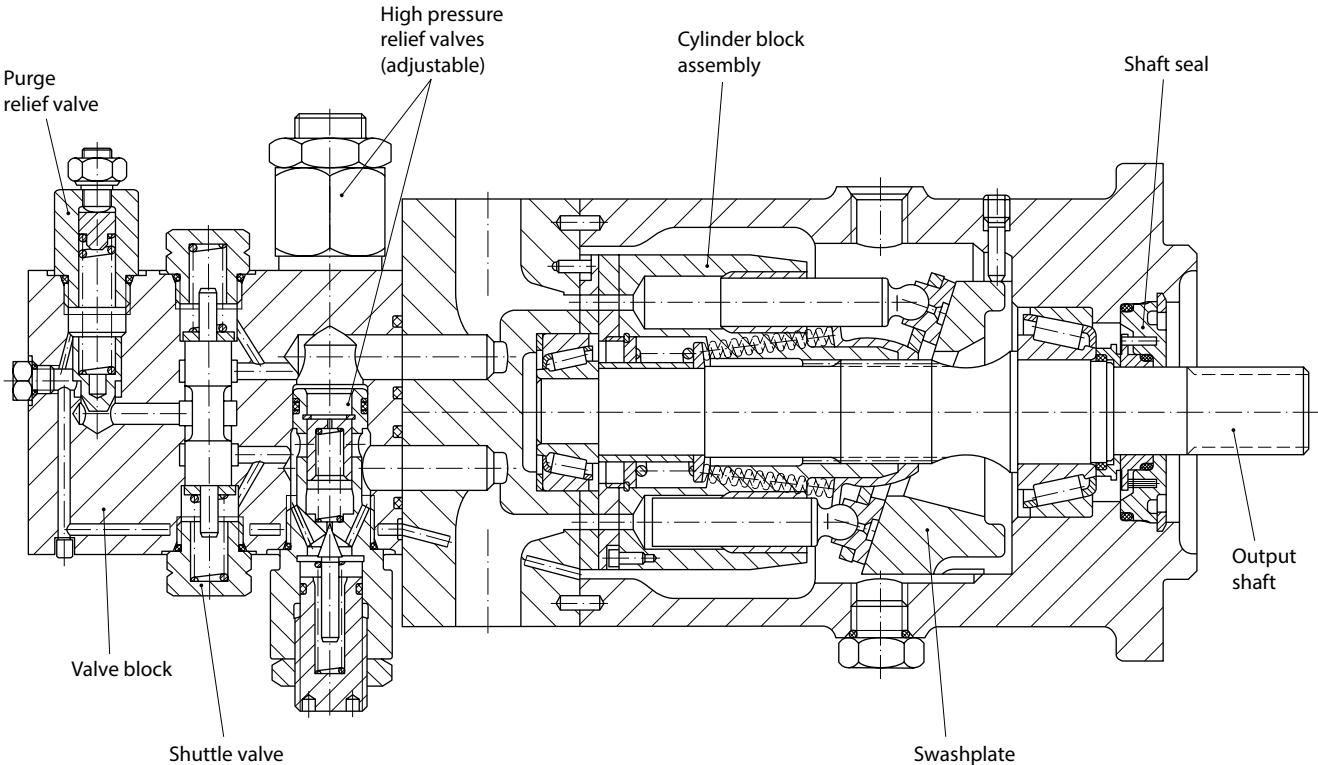

P005 118E

General Description

Pump and motor circuit description

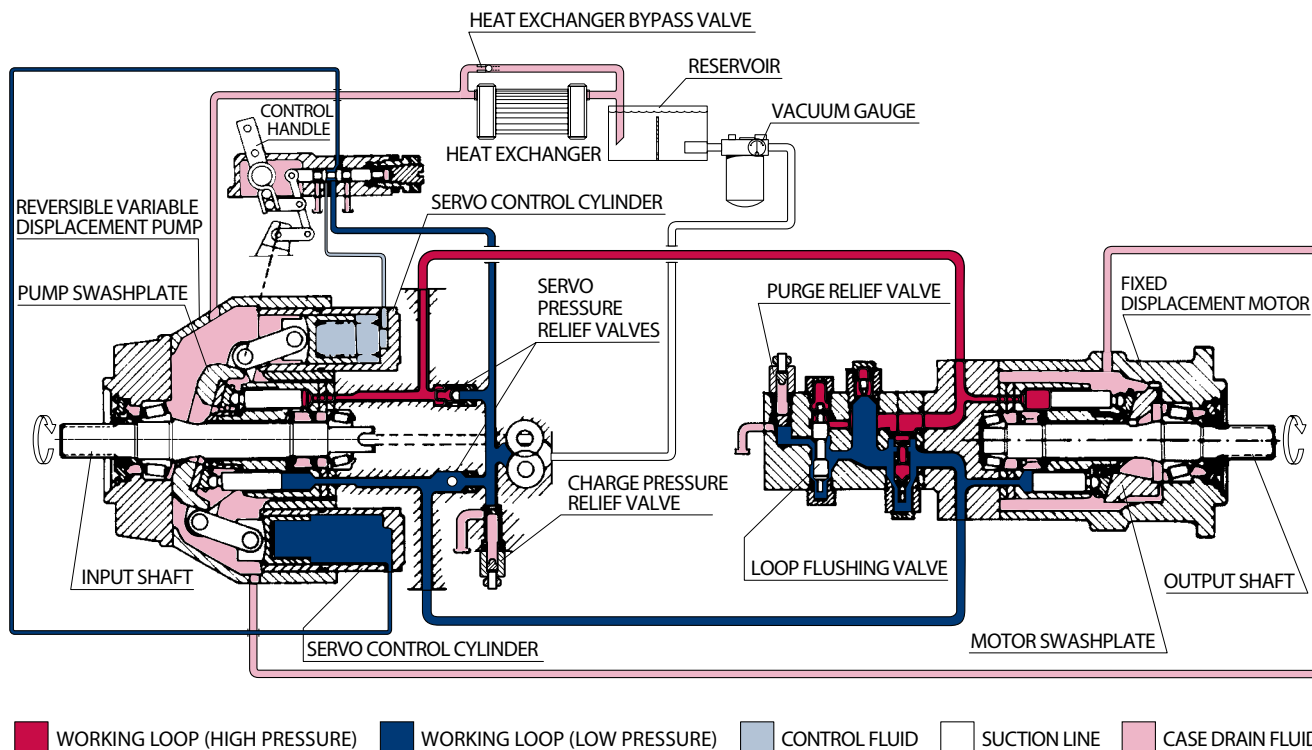

P000 027E

Above figure shows schematically the function of a hydrostatic transmission using an axial piston variable displacement pump and a fixed displacement motor.

Motor circuit schematic

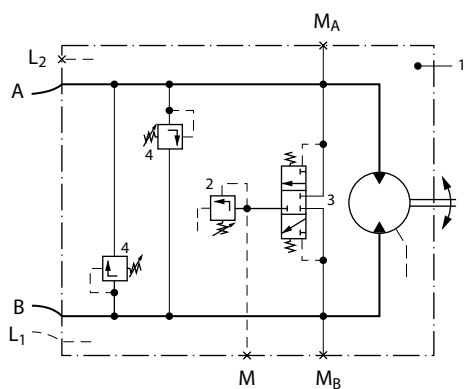

P000 034

Designation:

- 1 = Fixed displacement motor
- 2 = Purge relief valve
- 3 = Shuttle valve
- 4 = High pressure relief valve

Ports:

- A, B = Main pressure ports (working loop)
- L<sub>1</sub>, L<sub>2</sub> = Drain ports
- MA = Gauge port for port A
- MB = Gauge port for port B
- M = Gauge port - charge pressure

**Technical Specification**
**Technical parameters**
**Design**

Axial piston motor with fixed displacement and swash plate design.

**Type of mounting**

SAE four bolt flanges.

**Pipe connections**

Main pressure ports: SAE split flange

Remaining ports: SAE O-ring boss

**Direction of rotation and flow**

Clockwise or counterclockwise (viewing from the output shaft).

Direction of rotation	Port A	Port B
Clockwise (R)	Output	Input
Counterclockwise (L)	Input	Output

**Installation position**

Optional; motor housing must be always filled with hydraulic fluid.

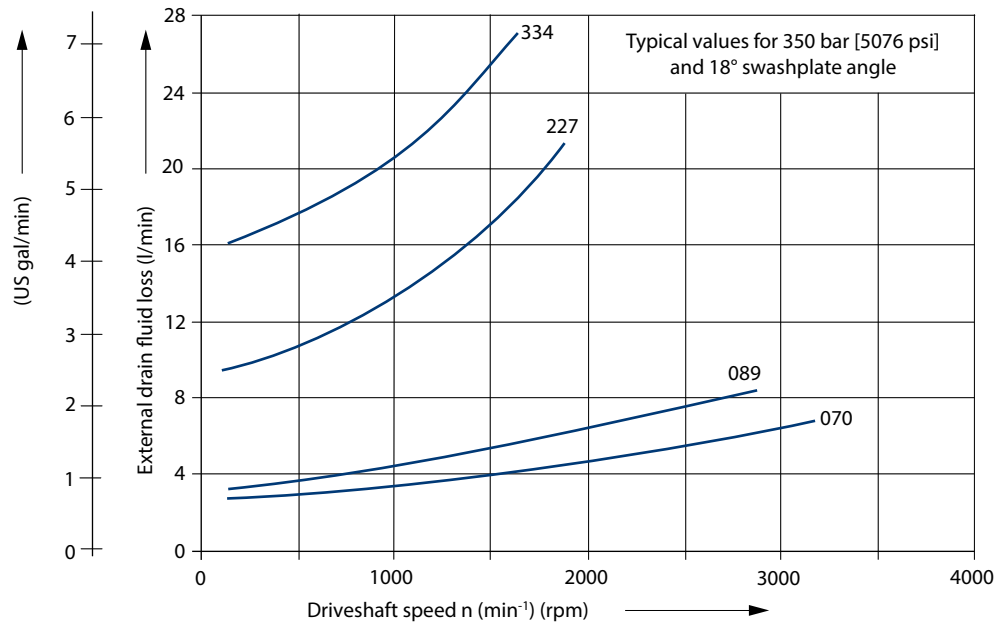
**External drain fluid loss**

P005 105E

**Technical Specification****Hydraulic parameters****System pressure range, input  $p_1$** 

Pressure on port A or B:

Max. operating pressure  $\Delta p = 420 \text{ bar [6092 psi]}$ Max. high pressure setting  $\Delta p = 460 \text{ bar}^1 \text{ [6672 psi]}$ <sup>1</sup>only with POR-valve**System pressure range, output  $p_2$** 

Normal setting for configuration MS and MR: 11.0 - 12.5 bar [160 - 181 psi] above case pressure.

Minimum: 8 bar, intermittent only

**Case pressure**

Max. rated pressure = 2.5 bar [36.3 psi]

Intermittent = 5.0 bar [72.5 psi]

**Hydraulic fluid**Refer to Danfoss publications [Hydraulic Fluids and Lubricants, 520L0463](#) and [Experience with Biodegradable Hydraulic Fluids, 520L0465](#).**Hydraulic fluid temperature range** $\vartheta_{\min} = -40 \text{ °C [- 40 °F]}$  $\vartheta_{\max} = 95 \text{ °C [203 °F]}$ **Viscosity range** $\nu_{\min} = 7 \text{ mm}^2/\text{s [49 SUS*]}$  $\nu_{\max} = 1000 \text{ mm}^2/\text{s [4630 SUS*]}$  (intermittent cold start)Recommended viscosity range: 12 - 60 mm<sup>2</sup>/s [66 - 278 SUS\*]

\*SUS (Saybolt Universal Second)

**Filtration**

Required cleanliness level: ISO 4406-1999 Code 22/18/13 or better.

Refer to Danfoss publications [Hydraulic Fluids and Lubricants, 520L0463](#) and [Design Guideline for Hydraulic Fluid Cleanliness, 520L0467](#).**Shaft load**

The pump will accept radial and axial loads on its shaft, the maximum capacity being determined by direction and point of application of the load.

Please contact your Danfoss representative.

**Technical Specification**
**Hydraulic parameters  
(continued)**
*Technical data*

		Frame size			
		070	089	227	334
Max. displacement	cm <sup>3</sup> [in <sup>3</sup> ]	69.8 [4.26]	89.0 [5.43]	227.3 [13.87]	333.7 [20.36]
Rated speed 1	min <sup>-1</sup> (rpm)	3200	2900	2100	1900
Theoretical torque	Nm/bar [in lb/1000 psi]	1.11 [677]	1.42 [867]	3.62 [2209]	5.31 [3240]
Mass moment of inertia of rotating group	kg m <sup>2</sup> · 10 <sup>-3</sup> [lbf·ft <sup>2</sup> · 10 <sup>-3</sup> ]	12.34 [292.8]	17.77 [421.7]	86.80 [2059.8]	161.40 [3830.0]

<sup>1</sup> for higher speeds contact your Danfoss representative

**Determination of nominal motor size**

Unit:	Metric System:		Inch System
<i>Input flow</i>	$Q_e = \frac{V_g \cdot n}{1000 \cdot \eta_v}$	l/min	$Q_e = \frac{V_g \cdot n}{231 \cdot \eta_v}$ [gpm]
<i>Output torque</i>	$M_e = \frac{V_g \cdot \Delta p \cdot \eta_m}{20 \cdot \pi}$	Nm	$M_e = \frac{V_g \cdot \Delta p \cdot \eta_m}{2 \cdot \pi}$ [lbf·in]
<i>Output power</i>	$P_e = \frac{Q_e \cdot \Delta p \cdot \eta_t}{600}$	kW	$P_e = \frac{V_g \cdot n \cdot \Delta p \cdot \eta_t}{396\,000}$ [hp]
<i>Speed</i>	$n = \frac{Q_e \cdot 1000 \cdot \eta_v}{V_g}$	min <sup>-1</sup>	$n = \frac{Q_e \cdot 231 \cdot \eta_v}{V_g}$ (rpm)

Efficiency characteristic curves available on request.

$V_g$	= Motor displacement per revolution	cm <sup>3</sup>	[in <sup>3</sup> ]
$n$	= Motor speed	min <sup>-1</sup>	(rpm)
$\Delta p$	= Hydraulic pressure differential	bar	[psid]
	$\Delta p = p_{HD} - p_{ND}$		
$\eta_v$	= Motor volumetric efficiency		
$\eta_m$	= Motor mechanical efficiency		
$\eta_t$	= Motor total efficiency		
$p_{HD}$	= High pressure	bar	[psid]
$p_{ND}$	= Low pressure	bar	[psid]

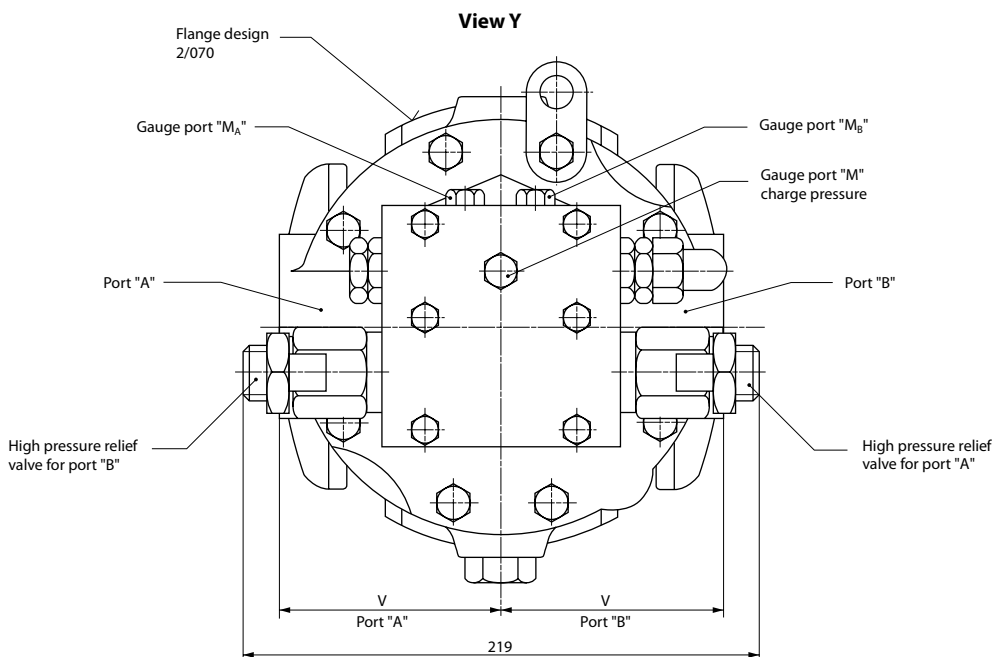
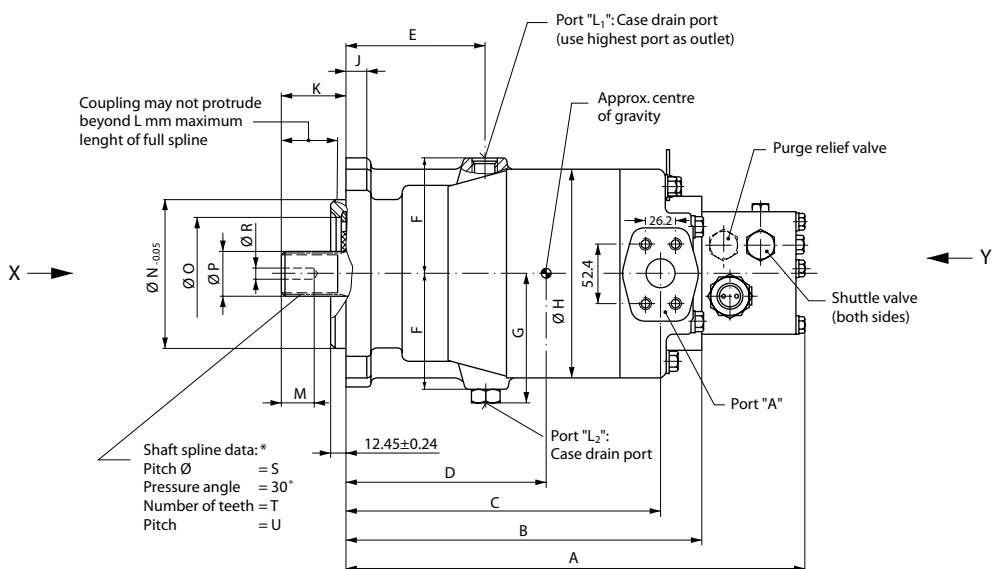

**Dimensions**

 – Frame Size 070 and 089 cm<sup>3</sup>
**Outline drawing, configuration MS**

\* Shaft spline data: spline shaft with involute spline, according to SAE handbook, 1963, class 1, fillet root side fit.

Frame size	Port A and B	Port L <sub>1</sub> and L <sub>2</sub>	Port M <sub>A</sub> and M <sub>B</sub>	Port M
070	SAE flange, size 1 SAE split flange boss 5000 psi 4 threads	7/8-14 UNF-2B SAE straight thread O-ring boss	7/16-20 UNF-2B SAE straight thread O-ring boss	
089	3/8-16 UNC-2B 18 deep			

Dimensions  
 – Frame Size 070 and 089 cm<sup>3</sup>

Outline drawing,  
 configuration MS  
 (continued)

View X (for SMF 2/070 only)

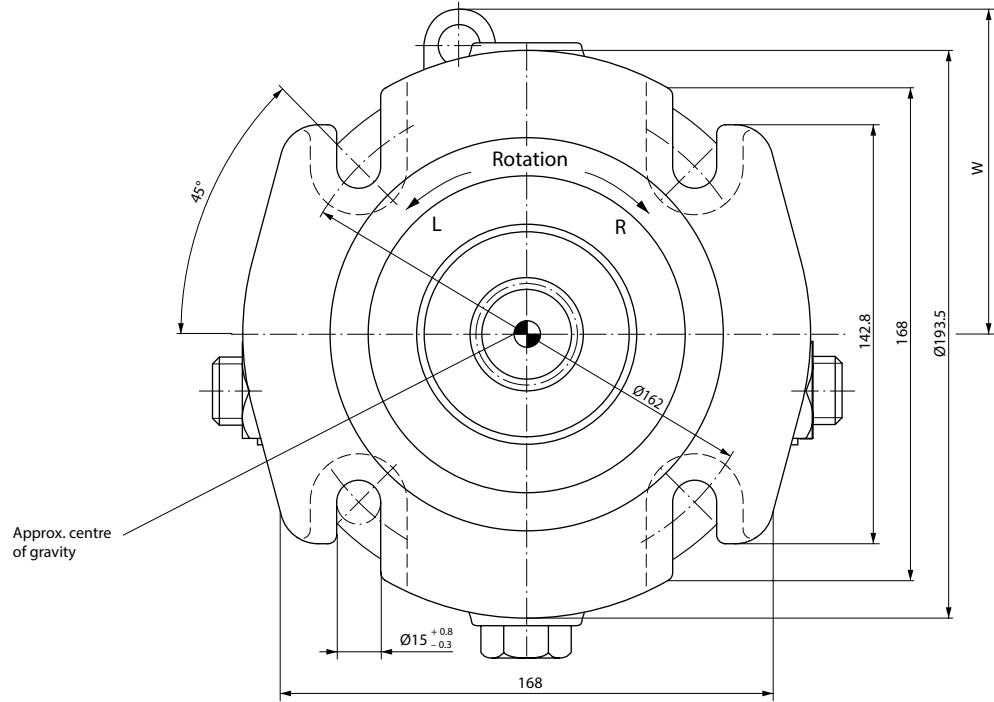

P005 119E

View X (for SMF 2/089 only)

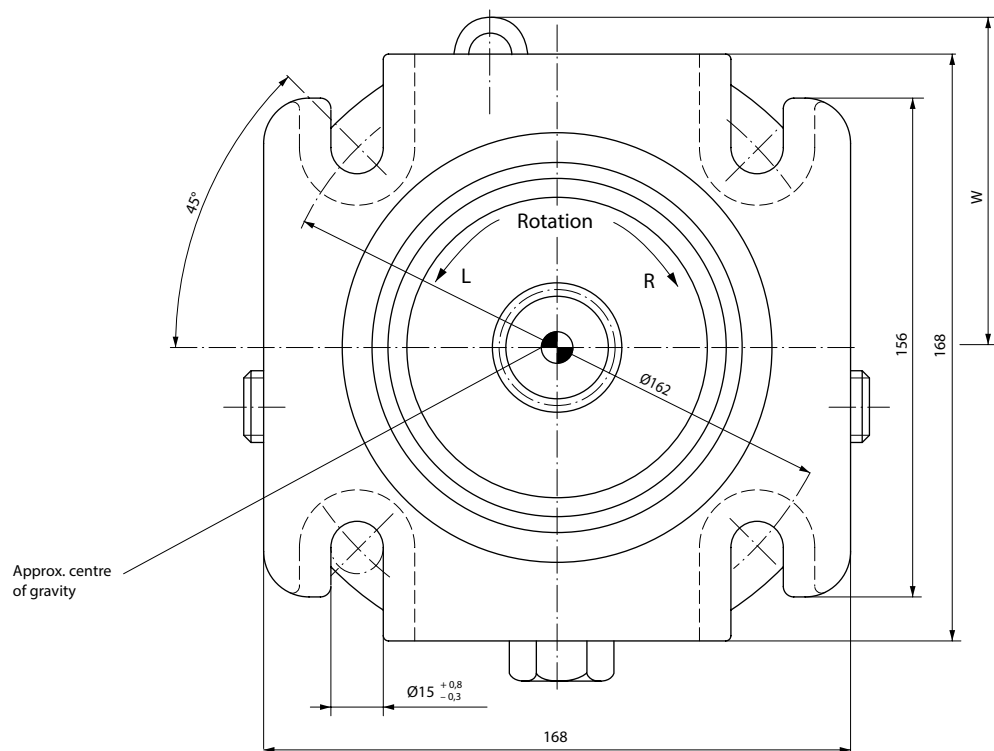

P005 120

**Dimensions**

 – Frame Size 070 and 089 cm<sup>3</sup>
**Outline drawing, configuration MS (continued)**
*Dimensions*

Frame size	A mm [in]	B mm [in]	C mm [in]	D mm [in]	E mm [in]	F mm [in]	G mm [in]	Ø H mm [in]	J mm [in]	K mm [in]	L mm [in]	M mm [in]
070	378 [14.882]	290 [11.417]	255 [10.039]	165 [6.496]	108 [4.252]	86.5 [3.406]	98 [3.858]	161 [6.339]	16 [0.630]	56 [2.205]	48 [1.890]	28.4 [1.118]
089	395 [15.551]	307 [12.087]	273 [10.748]	170 [6.693]	118 [4.646]	96.0 [3.780]	107 [4.213]	181 [7.126]	18 [0.709]	56 [2.205]	48 [1.890]	28.4 [1.118]
Frame size	Ø N mm [in]	Ø O mm [in]	Ø P mm [in]	Ø R mm [in]	Ø S mm [in]	T mm [in]	U mm [in]	V mm [in]	W mm [in]	Diameter for shaft coupling mm [in]	Weight kg [lb]	
070	127 [5.000]	84 [3.307]	34.50 <sup>-0.17</sup> [1.358 <sup>-0.0067</sup> ]	8.5 [0.335]	33.338 [1.313]	21 [0.827]	16/32	85.8 [3.378]	101 [3.976]	31.75 <sup>+0.062</sup> [1.250 <sup>+0.0024</sup> ]	40 [88]	
089	127 [5.000]	98 [3.858]	37.68 <sup>-0.17</sup> [1.483 <sup>-0.0067</sup> ]	8.5 [0.335]	36.513 [1.438]	23 [0.906]	16/32	95.2 [3.748]	114 [4.488]	34.95 <sup>+0.062</sup> [1.376 <sup>+0.0024</sup> ]	47 [104]	

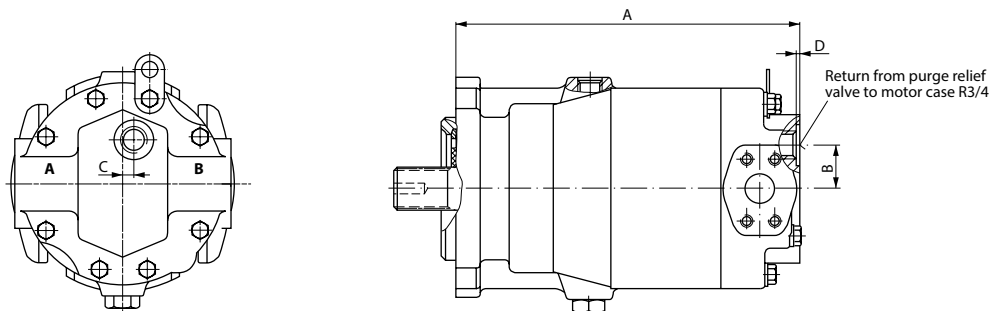
**Outline drawing, basic model**

P000 568E

*Dimensions*

Frame size	A mm [in]	B mm [in]	C mm [in]	D mm [in]	Weight kg [lb]
070	290 [11.417]	30 [1.181]	12 [0.472]	2 [0.079]	34 [75]
089	307 [12.087]	44 [1.732]	6 [0.236]		41 [90]

For further dimensions see previous pages.

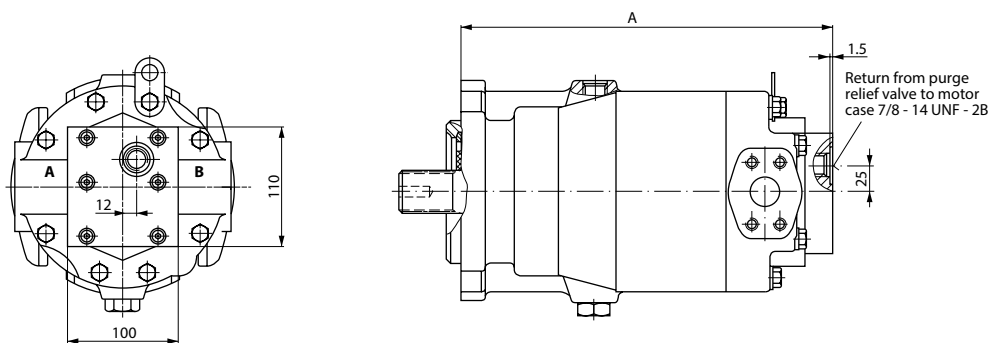
**Outline drawing, motor configuration AM 01000**

P000 569E

*Dimensions*

Frame size	A mm [in]	Weight <sup>1</sup> kg [lb]
070	315 [12.402]	36 [79]
089	332 [13.071]	43 [95]

<sup>1</sup> Light weight and short options available on request  
 For further dimensions see previous pages.

**Dimensions –  
Frame Size 070 and 089 cm<sup>3</sup>**

**Outline drawing, motor  
configuration MR**

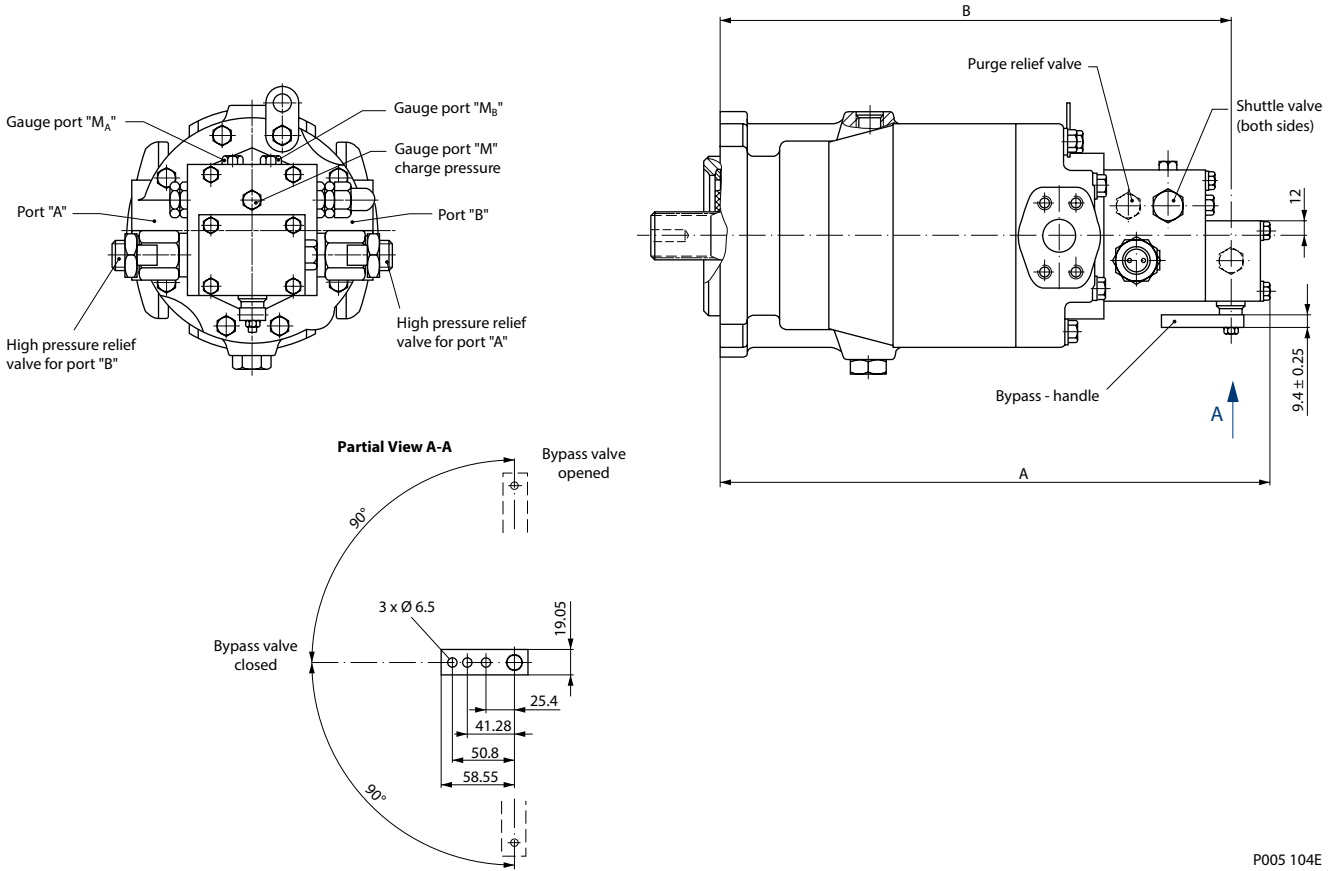

*Dimensions*

Frame size	A mm [in]	B mm [in]	Weight kg [lb]	Port M <sub>A</sub> and M <sub>B</sub>	Port M
070	426 [16.772]	391 [15.394]	42 [93]	7/16-20 UNF-2B SAE straight thread O-ring boss	
089	443 [17.441]	408 [16.063]	49 [108]		

For further dimensions see previous pages.

Dimensions

- Frame Size 070 and 089 cm<sup>3</sup>

Circuit diagrams

Configuration MR

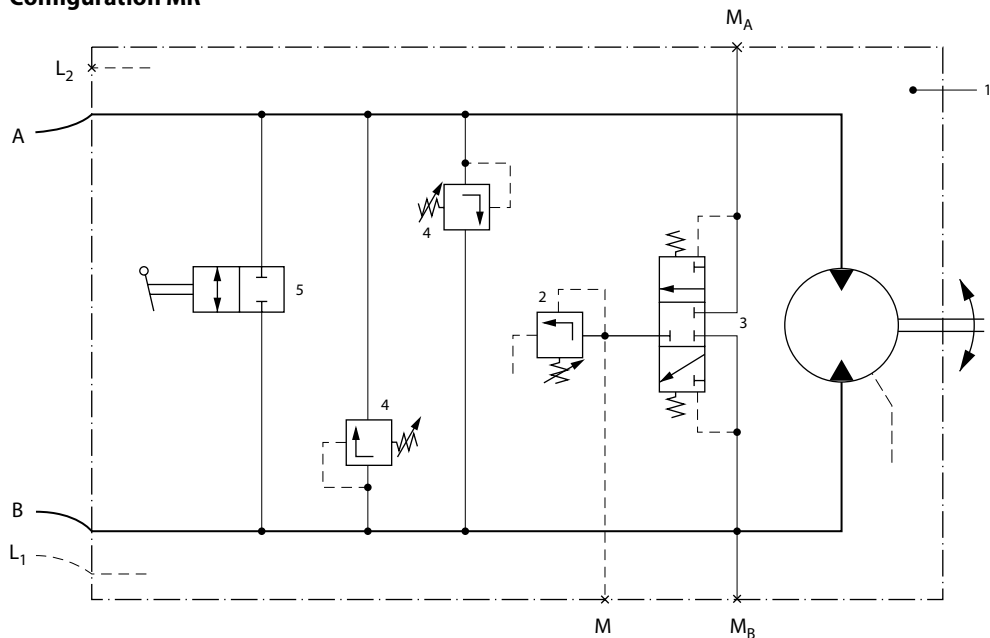

P000 035

Basic model and motor configuration AM 01000

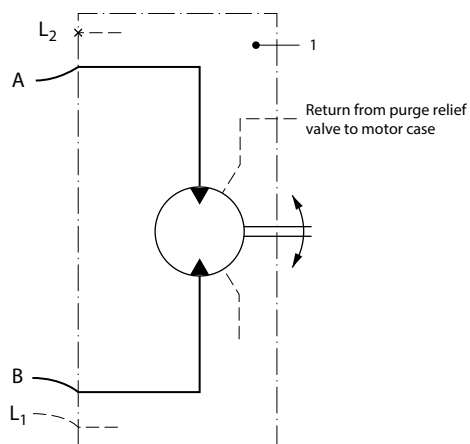

P000 038E

Designation:

- 1 = Fixed displacement motor
- 2 = Purge relief valve
- 3 = Shuttle valve
- 4 = High pressure relief valve
- 5 = Bypass valve

Ports:

- A,B = Main pressure ports (working loop)
- L<sub>1</sub>, L<sub>2</sub> = Drain ports
- M<sub>A</sub> = Gauge port for port **A**
- M<sub>B</sub> = Gauge port for port **B**
- M = Gauge port - charge pressure

## Technical Information Axial Piston Motors Series 20

### Dimensions – Frame Size 227 and 334 cm<sup>3</sup>

#### Outline drawing, configuration MS

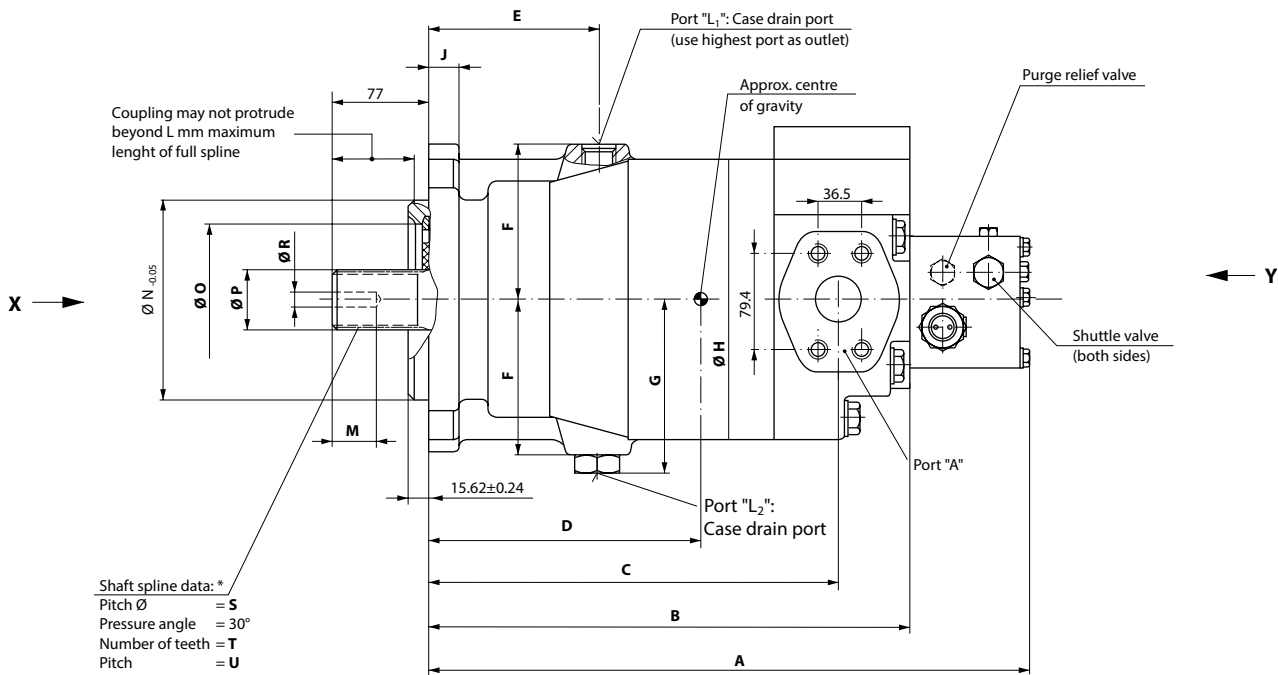

P005 100E-1

#### Dimensions

Frame size	A mm [in]	B mm [in]	C mm [in]	D mm [in]	E mm [in]	F mm [in]	G mm [in]	$\emptyset$ H mm [in]	J mm [in]
227	498 [19.606]	410 [16.142]	346 [13.622]	228.5 [8.996]	139.7 [5.500]	134.9 [5.311]	152 [5.984]	264 [10.394]	27 [1.063]
334	537 [21.142]	449 [17.677]	389 [15.315]	278 [10.945]	154 [6.063]	143. [5.650]	161 [6.339]	292 [11.496]	38 [1.496]
Frame size	M mm [in]	$\emptyset$ N mm [in]	$\emptyset$ O mm [in]	$\emptyset$ P mm [in]	$\emptyset$ R mm [in]	$\emptyset$ S mm [in]	T mm [in]	U mm [in]	V mm [in]
227	38.4 [1.512]	165.1 [6.500]	110 [4.331]	44.03 [1.733]	11.80 [0.465]	42.863 [1.688]	27 [1.063]	16/32	143.7 [5.657]
334	46.2 [1.819]	177.8 [7.000]	114 [4.488]	64.66 [2.546]	14.35 [0.565]	63.500 [2.500]	40 [1.575]	16/32	158.7 [6.248]
Frame size	W mm [in]	X mm [in]	Y mm [in]	Z mm [in]	AA mm [in]	BB mm [in]	CC mm [in]	Diameter for shaft coupling mm [in]	Weight kg [lb]
227	156 [6.142]	160 [6.299]	265 [10.433]	265 [10.433]	317.5 [12.500]	20.6 [0.811]	13 [0.512]	41.28 [1.625]	152 [335]
334	176 [6.929]	174 [6.850]	298 [11.732]	298 [11.732]	350 [13.780]	27.0 [1.063]	18 [0.709]	61.93 [2.438]	197 [434]

\* Shaft spline data: spline shaft with involute spline, according to SAE handbook, 1963, class 1, fillet root side fit.

## Technical Information      Axial Piston Motors Series 20

**Dimensions**  
 – Frame Size 227 and 334 cm<sup>3</sup>

**Outline drawing,  
 configuration MS  
 (continued)**

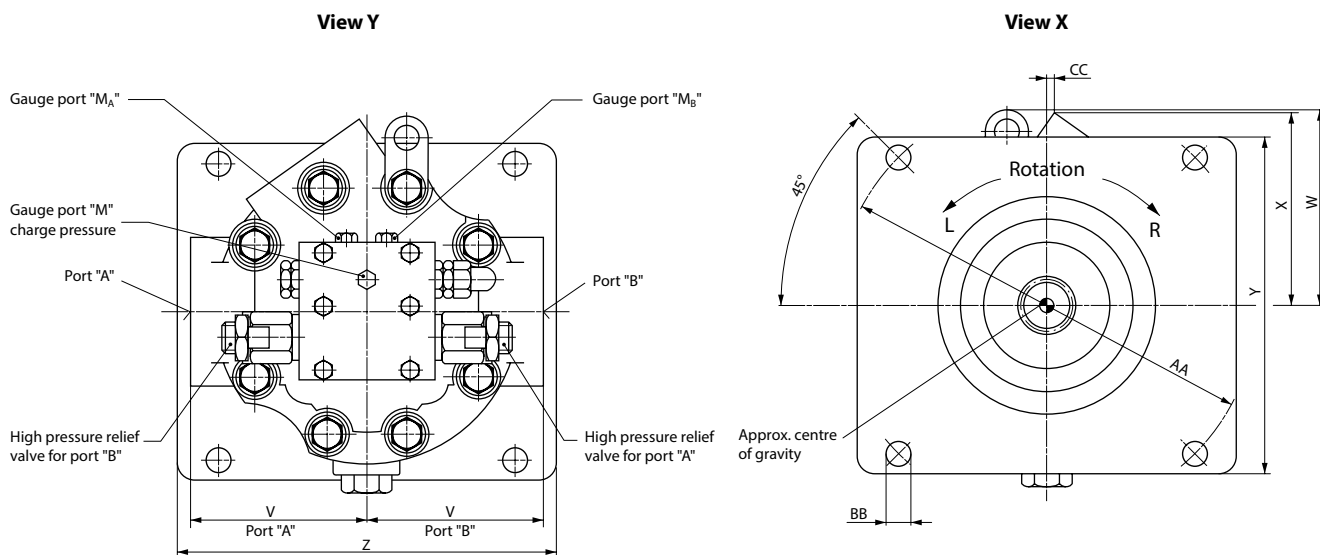

P005 100E-2

Frame size	Port A and B	Port L <sub>1</sub> and L <sub>2</sub>	Port M <sub>A</sub> and M <sub>B</sub>	Port M
227	SAE flange, size 1 1/2 SAE split flange boss 6000 psi 4 threads 5/8-11 UNC-2B 35 mm deep	1 7/8-12 UNF-2B SAE straight thread O-ring boss	7/16-20 UNF-2B SAE straight thread O-ring boss	
334				



**Products we offer:**

- Bent Axis Motors
- Closed Circuit Axial Piston Pumps and Motors
- Displays
- Electrohydraulic Power Steering
- Electrohydraulics
- Hydraulic Power Steering
- Integrated Systems
- Joysticks and Control Handles
- Microcontrollers and Software
- Open Circuit Axial Piston Pumps
- Orbital Motors
- PLUS+1® GUIDE
- Proportional Valves
- Sensors
- Steering
- Transit Mixer Drives

**Danfoss Power Solutions** is a global manufacturer and supplier of high-quality hydraulic and electronic components. We specialize in providing state-of-the-art technology and solutions that excel in the harsh operating conditions of the mobile off-highway market. Building on our extensive applications expertise, we work closely with our customers to ensure exceptional performance for a broad range of off-highway vehicles.

We help OEMs around the world speed up system development, reduce costs and bring vehicles to market faster.

Danfoss – Your Strongest Partner in Mobile Hydraulics.

**Go to [www.powersolutions.danfoss.com](http://www.powersolutions.danfoss.com) for further product information.**

Wherever off-highway vehicles are at work, so is Danfoss.

We offer expert worldwide support for our customers, ensuring the best possible solutions for outstanding performance. And with an extensive network of Global Service Partners, we also provide comprehensive global service for all of our components.

Please contact the Danfoss Power Solution representative nearest you.

**Comatrol**

[www.comatrol.com](http://www.comatrol.com)

**Schwarzmueller-Inverter**

[www.schwarzmueller-inverter.com](http://www.schwarzmueller-inverter.com)

**Turolla**

[www.turollaocg.com](http://www.turollaocg.com)

**Valmova**

[www.valmova.com](http://www.valmova.com)

**Hydro-Gear**

[www.hydro-gear.com](http://www.hydro-gear.com)

**Daikin-Sauer-Danfoss**

[www.daikin-sauer-danfoss.com](http://www.daikin-sauer-danfoss.com)

Local address:

**Danfoss Power Solutions (US) Company**  
2800 East 13th Street  
Ames, IA 50010, USA  
Phone: +1 515 239 6000

**Danfoss Power Solutions GmbH & Co. OHG**  
Krokamp 35  
D-24539 Neumünster, Germany  
Phone: +49 4321 871 0

**Danfoss Power Solutions ApS**  
Nordborgvej 81  
DK-6430 Nordborg, Denmark  
Phone: +45 7488 2222

**Danfoss Power Solutions Trading (Shanghai) Co., Ltd.**  
Building #22, No. 1000 Jin Hai Rd  
Jin Qiao, Pudong New District  
Shanghai, China 201206  
Phone: +86 21 3418 5200

Danfoss can accept no responsibility for possible errors in catalogues, brochures and other printed material. Danfoss reserves the right to alter its products without notice. This also applies to products already on order provided that such alterations can be made without changes being necessary in specifications already agreed. All trademarks in this material are property of the respective companies. Danfoss and the Danfoss logotype are trademarks of Danfoss A/S. All rights reserved.